



WideLink^(*) B600

AIS Class B Transponder
(SOTDMA)

USER MANUAL



Automatic Identification System

COPYRIGHT

The entire contents of this instruction manual, including any future updates, revisions, and modifications, shall remain the property of AMEC at all times. Unauthorized copies or reproduction of this manual, either in part or whole, in any form of print and electronic media, is prohibited. The contents herein can only be used for the intended purpose of this manual.

DISCLAIMER

AMEC is devoted to publish and maintain this product manual. As we continue to improve our AIS products to satisfy all customers' needs, information in this document is subject to change without notice. AMEC does not make any representations or warranties (implied or otherwise) regarding the accuracy and completeness of this document and shall in no event be liable for any loss of profit or any commercial damage, including but not limited to special, incidental, consequential, or other damage.

WARNING!

WARNING: The device must be installed and configured in conformity with the provided instructions in the manual by qualified installer in order to ensure the device performance.

WARNING: It is the responsibility of the operator to handle the AIS device with care. The device cannot replace human vigilance. Therefore it is important to keep a diligent outlook at all times.

WARNING: Please bear in mind that not all vessels are equipped with AIS transponders and therefore may not be visible to this device. Likewise, certain conditions, such as device malfunction, the environment, improper use, and overcrowded port traffic, may exist whereby the vessel equipped with this AIS device is not visible to other AIS transponders.

WARNING: DO NOT DISASSEMBLE OR MODIFY THE EQUIPMENT. Improper disassembly or modification could impair its performance and will invalidate the guarantee.

FOR USERS IN THE UNITED STATES OF AMERICA ONLY

WARNING: It is a violation of the rules of the Federal Communications Commission to input an MMSI that has not been properly assigned to the end user, or to otherwise input any inaccurate data in this device.

★ The entry of static data into this device shall be performed by the vendor of the device or by an appropriately qualified person in the business of installing marine communications equipment on board vessels.

★ Instructions on how to accurately enter and confirm static data in the device can be found in this user manual.

FOREWORD

We thank you for the purchase of your new WideLink B600, AIS SOTDMA class B transponder. Wherever you sail now, you can have a better overview of your surroundings at sea and voyage with more safety.

WideLink B600 is strictly tested to meet the rigorous demands of the marine environment. With proper installation and use, the equipment will serve loyally and reliably at its optimum.

For sales, services, and technical supports, please contact your local AMEC representatives or Alltek Marine Electronics Corp at sales@alltekmarine.com or service@alltekmarine.com. You are always welcome to visit our website at www.alltekmarine.com for new product status and company update.

Thank you again. Be safe.

TABLE OF CONTENT

1	SYSTEM OVERVIEW	7
1.1	PRODUCT DESCRIPTION	7
1.2	CLASS A vs. SOTDMA CLASS B vs. CSTDMA CLASS B	10
1.3	EQUIPMENT IN THE BOX	11
2	INSTALLATION	12
2.1	INSTALLATION PROCEDURES	12
2.2	MOUNTING DEVICE MAIN UNIT	13
2.3	VHF ANTENNA INSTALLATION	14
2.4	CONNECTING TO VHF RADIO (B600S ONLY)	15
2.4.1	FM radio connection (B600S only)	15
2.5	GPS ANTENNA INSTALLATION	16
2.6	CONNECTING WITH NMEA 0183 DEVICES	17
2.7	AIS SILENT MODE CONNECTION	18
2.8	CONNECTION TO NMEA 2000 NETWORK	19
2.9	CONNECTING TO A CHARTING PROGRAM VIA USB	20
2.10	CONNECTING POWER CABLE	21
3	CONFIGURING YOUR WIDELINK B600	22
3.1	CONNECTING TO YOUR AIS TRANSPONDER	22
3.1.1	Required Items	22
3.1.2	Installing "AIS Configuration Tool"	22
3.1.3	Three steps to connect the AIS transponder	23
3.1.4	Home page of the application	24
3.2	PROGRAMMING YOUR VESSEL DATA	25
4	GET STARTED	26
4.1	LED INDICATORS	26
4.2	MICRO SD CARD	27
4.2.1	Data Logging	27
4.2.2	Firmware Upgrade via Micro SD Card	27
4.3	WI-FI CONFIGURATION (WIDELINK B600W ONLY)	28
4.3.1	Access Point Mode	28
4.3.2	Client Mode	30
4.4	BUILT-IN INTEGRITY TEST (BIIT)	31
5	SPECIFICATIONS	32
5.1	PRODUCT SPECIFICATIONS	32
5.2	DIMENSIONS	34
5.3	SUPPORTED NMEA 2000 PGN AND TRANSLATION LIST	36
5.4	SUPPORTED NMEA 0183 SENTENCES	38
6	TROUBLESHOOTING	39
7	ABBREVIATIONS	41
8	FCC INTERFERENCE STATEMENT	42
9	RF EXPOSURE WARNING	43
	DECLARATION OF CONFORMITY	43
	INDUSTRY CANADA NOTICE	43

AMEC WORLDWIDE WARRANTY..... 44
APPENDIX: HOW TO DETERMINE SERIAL PORT 45



1 System Overview

1.1 Product Description

WideLink B600 is an SOTDMA AIS class B, the next evolution of AIS technology. Its 5W transmit power, higher reporting rate and professional grade time division management make B600 an overall more advanced product compared to AIS class B based on CSTDMA scheme.

Its enhanced housing with IPx7 waterproof and shock and temperature robustness is ideal to survive harsh marine environments. Chart plotter and PC can be easily integrated over its NMEA 2000, NMEA 0183 and waterproof USB port. Its integrated micro SD card can record AIS data and make firmware upgrade in the most intuitive way.

The WideLink B600 converts NMEA 2000 instrument data into NMEA 0183 sentences, such as heading, speed, depth, temperature, wind, pressure and so on. With the multiplexing function, sensor data along with AIS and GPS information can be displayed on chart plotters and PC programs. Its internal GNSS receiver with 72 channels supporting GPS and GLONASS by default and optional BeiDou and Galileo.

The integrated high-performance Wi-Fi (WideLink B600W only) together with AMEC AIS App makes your favorite smartphone or tablet a real-time AIS position plotter.

The built-in splitter (WideLink B600S only) featuring zero insertion loss on reception path and low insertion loss on transmission path ensures optimized range of your VHF radio and AIS transponder. Its self-test function gives a simple diagnosis in the event of antenna problem and system failure. It supports transparent mode to ensure priority to VHF radio operation even if the splitter has power failure.

WideLink B600/B600W

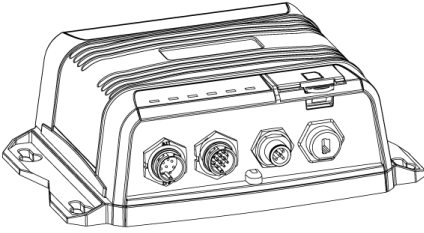

Front

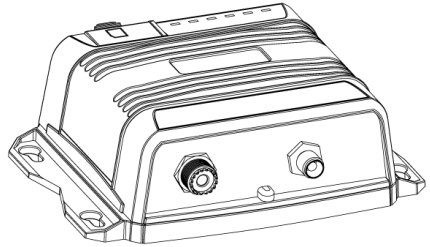

Back

WideLink B600S

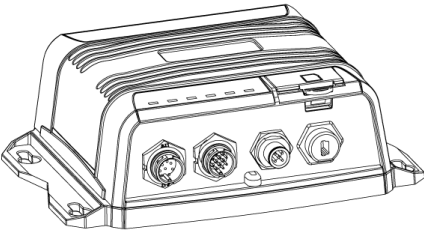

Front

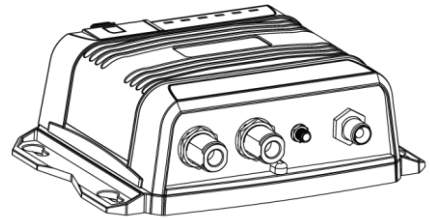

Back

B600 exchanges the following navigational data with other AIS equipped vessels within VHF range to increase the safety of your journey at sea:

- Static data:
 - Ship's name
 - Call sign
 - MMSI
 - Ship type
 - Location of GPS antenna on the ship
- Dynamic data:
 - Position of the vessel
 - Course over ground (COG)

- Speed over ground (SOG)
- True heading

The transponder receives also safety related messages (SRM) from other vessels or persons who are in distress.

SOTDMA Class B AIS broadcasts ship’s static data every 6 minutes. Ship dynamic data will be transmitted per following reporting interval:

Ship Speed	Nominal Reporting Interval	Increased reporting interval
>23 knots	Every 5 seconds	Every 15 seconds
between 14-23 knots	Every 15 seconds	Every 30 seconds
between 2-14 knots	Every 30 seconds	Every 30 seconds
≤ 2 knots or at anchored or moored	Every 3 minutes	Every 3 minutes

The Class B “SO” AIS follows the rules set by ITU-R M.1371-5, and increases the reporting interval to “Increased Reporting Interval” in accordance with Table above when less than 50 % of the slots of each of the last four consecutive frames are free. When more than 65 % of the slots of each of the last four consecutive frames are free, the Class B “SO” AIS reports at the “Nominal Reporting Interval”.

1.2 Class A vs. SOTDMA Class B vs. CSTDMA Class B

A brief comparison between class A and class B AIS is illustrated in the following table. WideLink B600 is an SOTDMA class B AIS transponder.

Type of AIS	Class A AIS	Class B SOTDMA	Class B CSTDMA
Primary Access Scheme	SOTDMA (Self-organizing)	SOTDMA (Self-organizing)	CSTDMA (Carrier-Sense)
Standard	IEC 61993-2	IEC 62287-2	IEC 62287-1
Transmit Power and range	12.5W	5W	2W
IMO Mandate	Mandatory for all SOLAS vessels	No mandate	No mandate
Reporting rate dynamic data	Highest (transmission up to every 2 sec)	Higher (transmission up to every 5 sec)	Low (transmission up to every 30 sec)
AIS data presented	Static, Dynamic, Voyage	Static and Dynamic data	Static and Dynamic data
Applications	Commercial vessels, fishing boats, working boats, passenger boats with more than 12 passengers	Smaller commercial, fishing and work boats, recreational vessels	Recreational vessels and small fishing boats

1.3 Equipment in the Box

Upon receiving the product please verify items in the box. If any is missing, please contact your local AMEC representative immediately.



AIS SOTDMA Class B Transponder



12pin data cable



8pin power cable



Mini USB to USB cable



TP3x3/4 Screws



User Manual



VHF Radio Cable
(PL259-PL259)
(B600S only)



FM Radio Cable
(SMA-Motorola Jack)
(B600S only)

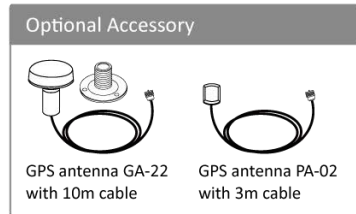

2 Installation

2.1 Installation Procedures

Please familiarize the manual content before installation. Depending on your hardware configuration, use the following recommended steps to install the device.

- 1) Mount the device unit to an appropriate location
- 2) Install VHF antenna
- 3) Connect to VHF radio (B600S only)
- 4) Connect to FM radio (B600S only)
- 5) Install GPS antenna
- 6) Connect to a chart plotter and/or other instruments via NMEA 0183, NMEA 2000 or USB
- 7) Connect to a Tx switch box and/or external alarm system (optional)
- 8) Connect to an appropriate power source (12V / 24V DC, 2A)

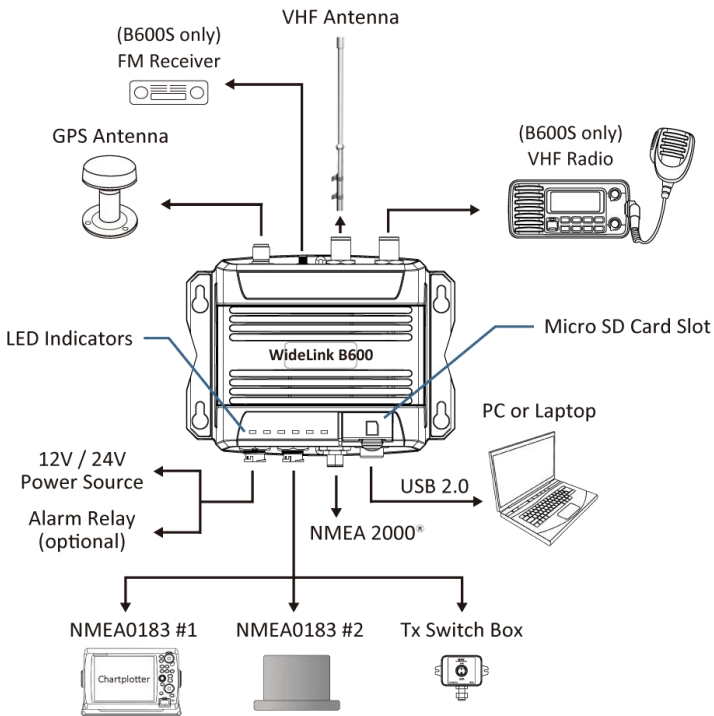

Figure 1 External Connections

2.2 Mounting Device Main Unit

The following guidelines should be noticed when selecting the environment to install your AMEC WideLink B600:

- Do not install the device in a flammable or hazardous atmosphere such as in an engine or generator room or close to fuel tanks.
- Installation of the device should be undertaken in a safe environment without being exposed to any splashing water or rain.
- There should be adequate space around the device for routing of cables. See figure below for details of the device dimensions.
- The safe distance of the device to any magnetic compass is at least 0.3m.
- The operating temperature is between -15°C and $+55^{\circ}\text{C}$.
- The device can be installed and mounted on a flat surface, or it can be mounted on the wall with the four self-tapping screws supplied.
- The device should be mounted in a location where the indicators can readily be observed as these indicators deliver relevant information on the status of the device.
- For safety reasons, it's recommended to mount the device not higher than 2m (78.74") above floor-level.

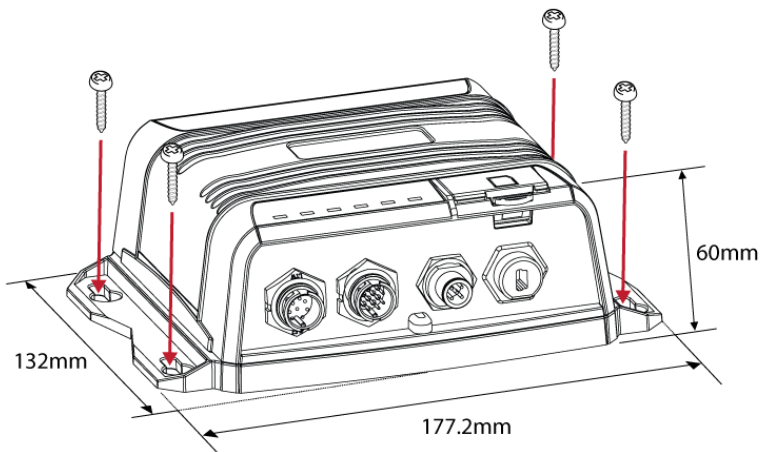

Figure 2 Mounting the Device

2.3 VHF Antenna Installation

The quality and positioning of the antenna are the most important factors dictating AIS performance. It is recommended that a VHF antenna with omnidirectional vertical polarization be specifically tuned for marine band. Since the range of VHF signals is largely decided by line of sight distance, the VHF antenna should be placed as high as possible and at least 5 meters away from any constructions made of conductive materials.

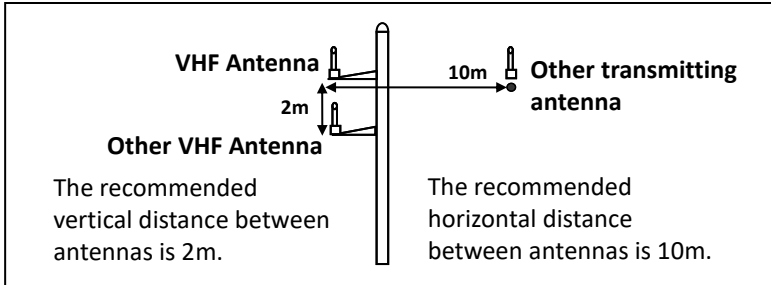

Figure 3 VHF Antenna Locations

The VHF antenna connector type on Wideline B600 is SO239 which is designed to work with a PL259 connector.

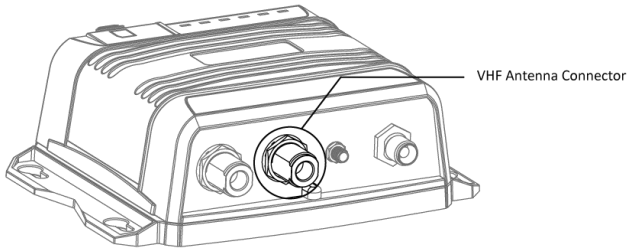

Figure 4 VHF Antenna Connector

2.4 Connecting to VHF Radio (B600S only)

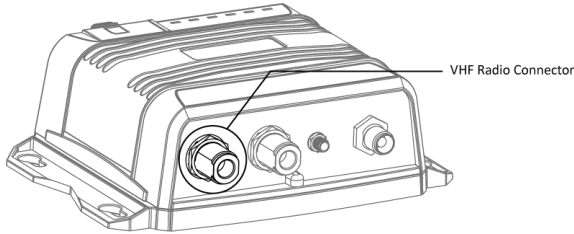

Figure 5 VHF Antenna Connector

It is important for users to make sure that the VHF radio is always connected to the VHF radio input port (left SO-239 connector) – and never connected to antenna input port. When VHF radio is connected to antenna input port, the AIS receiver of WideLink B600S might be severely damaged.

The internal path for VHF radio stays transparent also when WideLink B600S is switched off or has power failure. WideLink B600S is designed to give priority to VHF radio in the event of simultaneous transmission of VHF radio and AIS.

In case VHF radio is not connected to WideLink B600S, the VHF radio connector should stay floating or be connected with a 50ohm dummy load.

2.4.1 FM radio connection (B600S only)

Use the Motorola jack of the attached FM radio cable to connect to radio's female receptacle. For best FM radio reception, make sure the VHF antenna is extended to the highest achievable position.

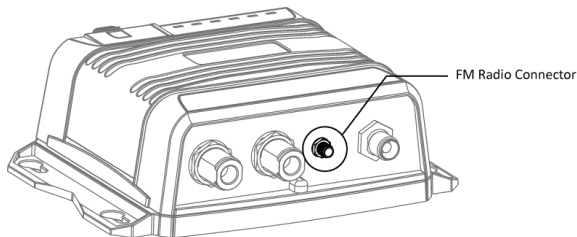

Figure 6 FM Radio Connector

2.5 GPS Antenna Installation

Install the GPS antenna where it has a clear view to the sky, so that it may access the horizon freely with 360° degrees.

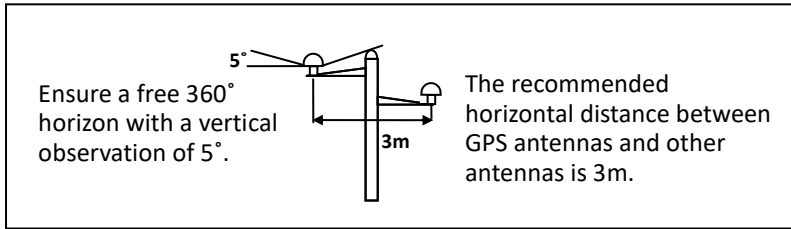

Figure 7 GPS Antenna Locations

It is recommended to keep the GPS antenna out of the transmitting beam of high-power transmitters such as Inmarsat devices and radar.

When connecting the cables, take note of the following precautions.

- Bending cables may cause damages to the inner wires and impair overall the performances.
- Each coaxial cable should be set up separately and can only be set up in a single cable tube.
- Insulation on connector port of the coaxial cable should be considered.

WideLink B600 is tested and certified with the GPS antenna GA-22. It's recommended to use GA-22 with B600 series to ensure optimal reliability of your AIS system.

2.6 Connecting with NMEA 0183 Devices

WideLink B600 supports two NMEA 0183 ports and external silent mode switch with its 12-pin data cable. The default NMEA 0183 baud rates are 38400-bps (high speed) and 4800-bps (low speed). The baud rates can be changed with the provided configuration tool. Typically the high-speed setting is primarily for chart plotter connection, while the low-speed setting can be used for NMEA 0183 compatible instruments.

WideLink B600 NMEA 0183 supports multiplexer function. Received NMEA 0183 data from both ports will be multiplexed and forwarded to all output ports as well as USB and Wi-Fi (B600W only).

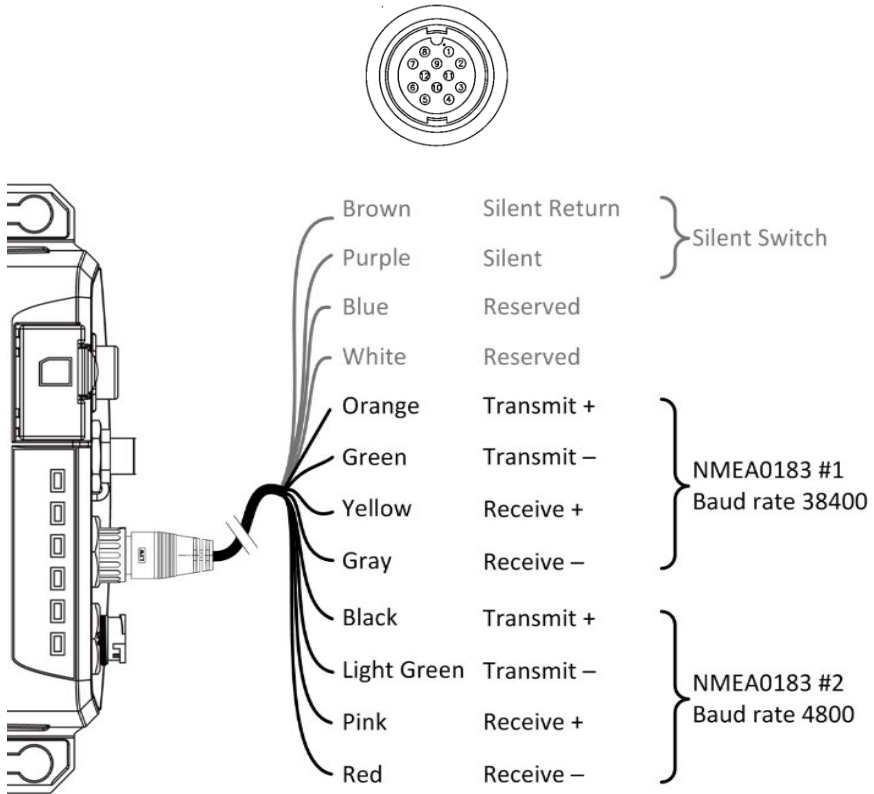

Figure 8 NMEA 0183 Connection



Warning: During installation, you may have to peel off some wires to make the appropriate connections. After completing the installation, please cover all exposed wires with a rubber-vulcanized tape to prevent the devices from malfunctioning or short-circuited.

2.7 AIS Silent Mode Connection

When Silent Mode is required, it is possible to connect an external toggle switch to WideLink B600. Connect the toggle switch between the purple and brown wires to enable Silent Mode function, as depicted in Figure below. An optional Tx Switch Box (part number SB-181) is available from AMEC for Silent Mode activation.

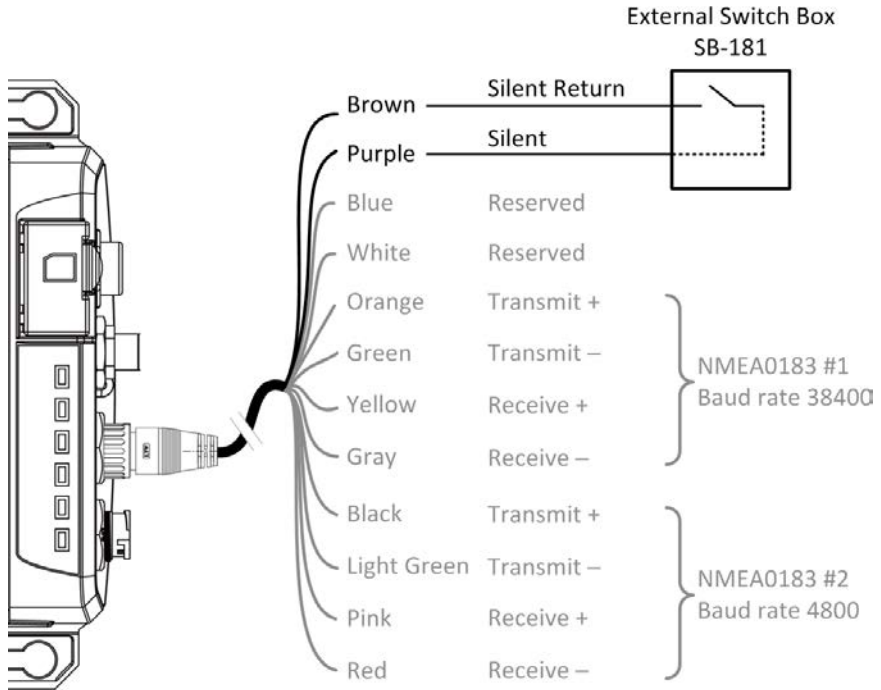

Figure 9 Silent Switch Connection

2.8 Connection to NMEA 2000 Network

The Widelink B600 is equipped with NMEA 2000 interface with LEN=1. The device is able to send AIS data and forward received GPS data (from NMEA 0183) via NMEA 2000 network to other NMEA 2000 devices. For further applications e.g. heading sensor connection, please refer to supported PGN in 5.3. An updated PGN list is available at AMEC website under Support/FAQ.

A compatible T-connector and drop cable/spur available by your local service partner are needed to connect the device to your chart plotter with NMEA 2000 interface:

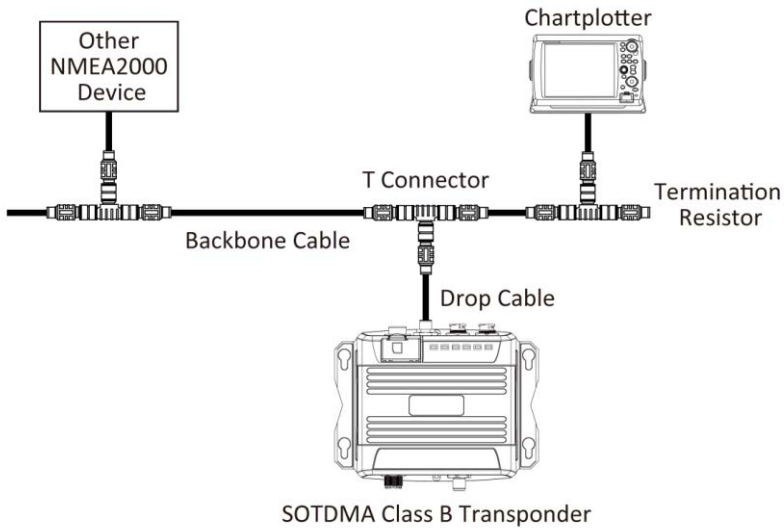

Figure 10 NMEA 2000 Network

B600 converts several practical NMEA 2000 PGN into NMEA 0183 sentences and outputs them on NMEA 0183, USB and Wi-Fi (B600W only). Please refer to the Supported NMEA 2000 PGN and Translation List in 5.3 or on AMEC website at www.alltekmarine.com/support under B600.

The conversion function is off by default. To enable the function, users must check the box in AMEC AIS Configuration Tool under the tab Configuration/Advanced Configuration.

2.9 Connecting to a charting program via USB

Your transponder can be used as a source of AIS for electronic charting and navigation program (PC/Mac) such as NaviPro, TimeZero, Coastal Explorer or OpenCPN etc. Follow the steps below to connect the transponder to the software:

- Connect the transponder to your PC or Mac using the USB cable that comes with the package. In most cases, the USB driver will be installed automatically. When it's not the case, you can find the driver from our website www.alltekmarine.com/support/download and install it manually.
- Make sure the baud rate is set at 115200. The data port can be confirmed by running the Device Manager on your computer or be detected automatically depending on the software.

2.10 Connecting Power Cable

Connect the WideLink B600 to vessel's power source as illustrated below. The device requires a 12V or 24V DC power supply (9.6 to 31.2V) capable of supplying 2A peak current @12V DC. Always use a minimum 3A fuse panel before connecting directly to battery or power supply. Power on the power source will turn on the device unit automatically.

B600's power cables are marked with bullet connectors.

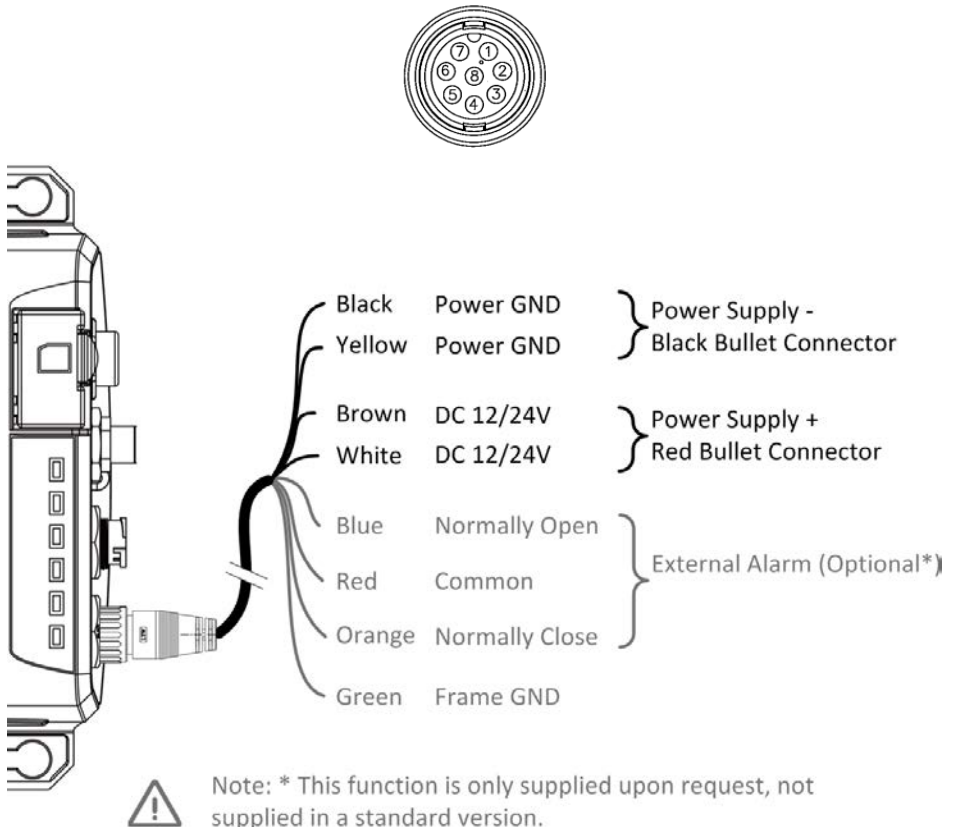

Figure 11 Power and Alarm Connection

3 Configuring Your WideLink B600

Your WideLink B600 is delivered with a power “AIS Configuration Tool” allowing users to set up the transponder and make a real-time diagnosis. A more detailed user guide of configuration tool can be found in the “Help” of the software.

3.1 Connecting to your AIS Transponder

3.1.1 Required Items

Before preceding the configuration procedure, make sure the following items are available:

- AIS Configuration Tool (PC/Mac) and USB driver which are available for download from www.alltekmarine.com/support/download
- USB cable (included in the box)
- Mac OS X 10.6 and later or Microsoft® Windows® (including both 32 and 64-bit versions)
- One available USB port on PC/Mac



Note: For configuration and firmware upgrade purpose, B600 series can be powered only by USB. When USB power is in use, the device will not transmit any data. To configure the Wi-Fi of B600W, a regular 12/24V DC power supply is required.

3.1.2 Installing “AIS Configuration Tool”

The “AIS Configuration Tool” must be installed before connecting your transponder to your PC or Mac.

The AIS Configuration Tool (PC/Mac) is available for download from www.alltekmarine.com/support/download. Unzip the downloaded file and navigate to the folder for

Windows: Double-click the ‘setup.exe’ item to start the installer and follow the on-screen instructions.

Mac: Double-click the ‘AISConfigurationTool.dmg’ file. A new Finder window will open and drag the “AIS Configuration Tool” to the Applications folder to complete the installation process.

You can now launch the application from the Windows® Start menu or the Mac Applications folder.

3.1.3 Three steps to connect the AIS transponder

Step 1:

Connect your Class B AIS transponder to your PC or Mac using a USB cable. In most cases the USB driver will be installed automatically by Windows system. When USB driver installation is not done automatically, you can find the driver from our website www.alltekmarine.com/support/download and install it manually. Follow the on-screen instructions and assign the correct file path of the USB driver to complete the installation. You can also install the USB driver via the Device Manager in the Control Panel.

Step 2:

Select the “Com Port” corresponding to your AIS transponder from the drop down menu at the top left of the application window, the Com Port will normally be listed as “AIS Virtual Com”.

Step 3:

Click the ‘Connect’ button. In a short moment, the button will be displayed as “Disconnect” when the connection is established.

3.1.4 Home page of the application

The application is now communicating with your AIS transponder and will display any pre-configured vessel data on the 'Home' page depicted as follows.

The screenshot shows the 'AIS Configuration Tool' interface. At the top, there is a 'Com Port' field set to 'COM2' and a 'Disconnect' button. The main area is divided into five panels:

- Configuration:** Displays 'Ship's Name', 'Call Sign', 'MMSI', and 'Vessel Type'. The 'Vessel Type' is set to '37 = Vessel-Pleasure craft'. A 'More...' link is at the bottom right.
- Diagnostics:** Displays 'Product Serial Number' and 'Product Firmware Version' which is 'V1.1.5.03'. A 'More...' link is at the bottom right.
- GNSS Status:** Shows a satellite image of Earth with a crosshair and cardinal directions (N, S, E, W). A 'More...' link is at the bottom right.
- Other Vessels:** A table listing nearby vessels with columns for MMSI, Ship's Name, Call Sign, Range (NM), and Bearing (°).
- Wi-Fi:** This section is highlighted with a red border. It shows 'Wi-Fi Mode: Access Point' and 'Wi-Fi Module Firmware Version: 1.2.5'. A 'More...' link is at the bottom right.

MMSI	Ship's Name	Call Sign	Range (NM)	Bearing (°)
001193046	NAUTICAST	D11233	--	--
100000000			--	--
209370000			--	--
372462000			--	--
416000032			--	--

Wi-Fi setting is only available when Wi-Fi module on the AIS device is detected.

3.2 Programming your vessel data

After the device is successfully connected with the Configuration Tool, click on the “Configuration” tab. You will require the following information in order to configure the device:

- Vessel’s name: limited to 20 characters
- Call sign: limited to 7 characters
- MMSI: Enter your MMSI (Maritime Mobile Service Identity) number
- Vessel type: choose your ship type from the drop down list
- Ship dimensions: Enter the vessel dimensions by appointing the position of your GPS antenna
- Configure NMEA 0183 Baud Rate: Baud rate of NMEA 0183 # 1 and NMEA 0183 # 2 can be configured here to 38400, 9600 or 4800.



WARNING: The MMSI number can only be entered once. Be sure to enter the correct MMSI number, as it cannot be corrected if entered incorrectly.

The screenshot shows the AIS Configuration Tool interface. At the top, the 'Com Port' is set to 'USB Serial Port (COM8)' with a 'Disconnect' button. The 'Configuration' tab is active, showing several sections:

- Configure Vessel Details:** Fields for Ship's Name, Call Sign, MMSI (with a help icon), and Vessel Type (set to '37 = Vessel-Pleasure craft').
- Ship Dimensions and GPS Antenna Location:** A diagram of a vessel with dimensions A, B, C, and D. To the right are four numeric input fields for A, B, C, and D, each with a minus, zero, and plus button, and a unit 'm'.
- Configure NMEA0183 Baud Rate:** Two dropdown menus for NMEA 1 and NMEA 2, both set to '38400'.
- Advanced Configuration:** A 'More...' button.

At the bottom center, there is a 'Program Device' button.

Figure 12 Static Data Setting

4 GET STARTED

The device starts up whenever the connected power source is ON. It will operate automatically when the device has been properly configured and GPS/VHF antennas are properly installed. The device transmits its own ship positions depending on vessel's moving speed and should receive information of other vessels in the vicinity. The operation status of the device can be observed with the LED lights on the unit. Description of the LED indications is provided in the following section.

4.1 LED Indicators

Indicator	Light	Description
Power	Green, steady	The device has been powered up correctly. By USB power, the Power LED does not light showing that the device is in low power mode.
Tx / Silent	Green, flashing	The device is transmitting AIS data. The flashing interval varies depending on vessel speed.
	Green, steady (B600S only)	The VHF radio is transmitting
	Orange, steady	The device is in silent mode, no AIS transmission at all.
Rx	Green, flashing	The device is receiving AIS data.
SD	Green, flashing	SD card is being accessed.
	Green, steady	SD card is inaccessible due to malfunction.
Wi-Fi (B600W)	Green, flashing	The green LED indicates an active Wi-Fi traffic
Error	Red, steady	MMSI is not properly programmed
	Red, flashing	A BIIT system error is detected referring to chapter 4.4, or by USB power
Warning (B600S)	Orange, steady	The orange LED illuminates when antenna VSWR is over 3:1 by VHF transmission at 25W.

4.2 Micro SD Card

4.2.1 Data Logging

The Widelink B600 records voyage data onto a micro SD card in the .txt format. The compatible micro SD card types are listed as follows:

- Standard “SD” with maximum 2GB size
- Standard “SDHC” with maximum 32GB size
- Supported data format: FAT12/16 by SD, FAT32 by SDHC

Insert the Micro SD card into the slot as shown below and data logging will start immediately. When the device begins recording, the green SD LED indicator blinks. When recorded data gets full, it overwrites new data as deleting from the oldest data. Removing Micro SD card from the device stops data logging immediately, and the SD LED will turn off.

The log files have a naming convention of AIS_XXXXXX.txt with increment from 000001 to 999999. Entry in the log file is vessel’s GPS sentence in IEC61162 format. The log file can be read by chart plotting PC software like AMEC AIS Viewer or NaviPro ECS.

It’s recommended to format your SD card regularly, e.g. every 1~3 month for optimal data integrity. Please save any data you wish to keep prior to formatting your memory card.

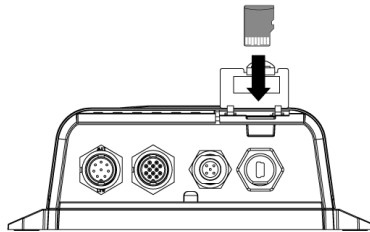

Figure 13 Inserting SD Memory Card

4.2.2 Firmware Upgrade via Micro SD Card

Unzip the B600_SD_Firmware.zip upgrade package in the root folder of a Micro SD card and make sure the both files APPS600.BIN & Firmware.csv are included.

Disconnect B600 from power supply and insert the Micro SD card into B600. Power on the B600 and the firmware upgrade will start automatically when the transponder detects the presence of the required files. All the LED will stay ON during the upgrade process which will be completed in 20 seconds.

Please notice that firmware upgrade will only take place when the Micro SD card is inserted into the B600 while it is powered off.

4.3 Wi-Fi Configuration (WideLink B600W only)

WideLink B600W is featured with high-performance Wi-Fi module and built-in Wi-Fi antenna. It can work in Access Point Mode or Client Mode. The information below details the information required for connecting the WideLink B600W to mobile devices using Wi-Fi.

4.3.1 Access Point Mode

WideLink B600W supports wireless connection with up to 32 mobile devices in AP mode. After the configuration is done, press “Program Wi-Fi Module” to save the settings to the device.

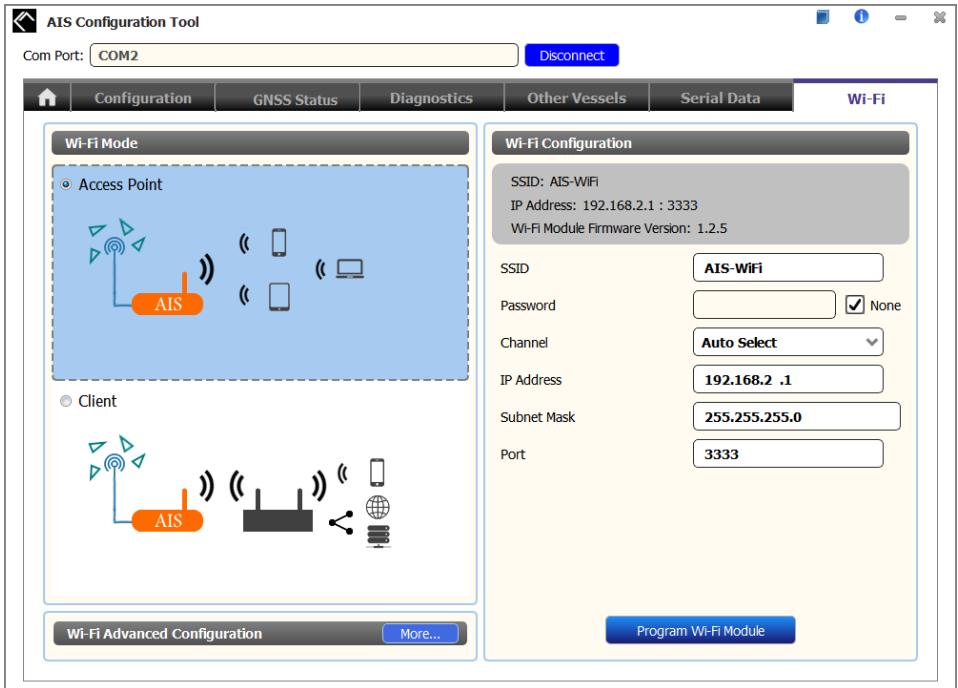

Figure 14 Access Point Mode

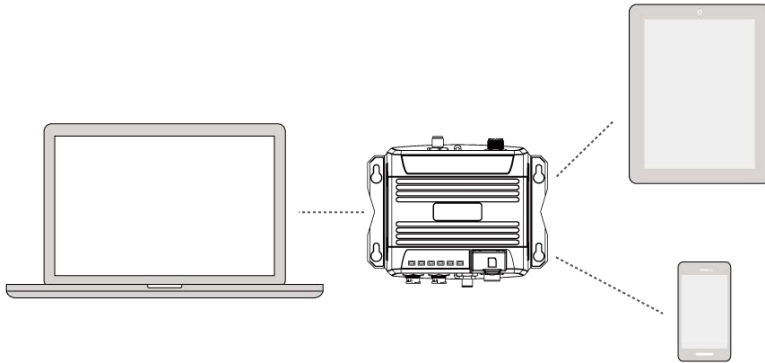

Figure 15 Connect to Mobile Devices

■ **SSID (Service Set Identifier):**

The SSID for the WideLink B600W is AIS-WiFi. When another SSID is preferred, just input it in the SSID field and then press “Program Wi-Fi Module”.

■ **Password:**

By default the Wi-Fi network has no password. Users are allowed to create their own key with an alpha-numeric password between 8 and 63 characters long. The password can include symbols (!?*&_) and spaces.

■ **Channel:**

The default setting is Auto Select to let the device select the best channel. When needed, choose a channel that's free from other sources of interference.

■ **IP Address:**

Default system IP is **192.168.2.1**

User can create IP by inputting value in individual field.

■ **Port:**

The default port is **3333**. The available port range is between 3000-65535.



Note: By default, AMEC WideLink B600W uses WPA2-Personal wireless security protocol.

4.3.2 Client Mode

Widelink B600W is able to join an existing Wi-Fi network. When clicking on „Client”, it can take about 45 seconds until the device scans all available Wi-Fi networks. Pick the network you want to join and enter the password and click on “Connect”.

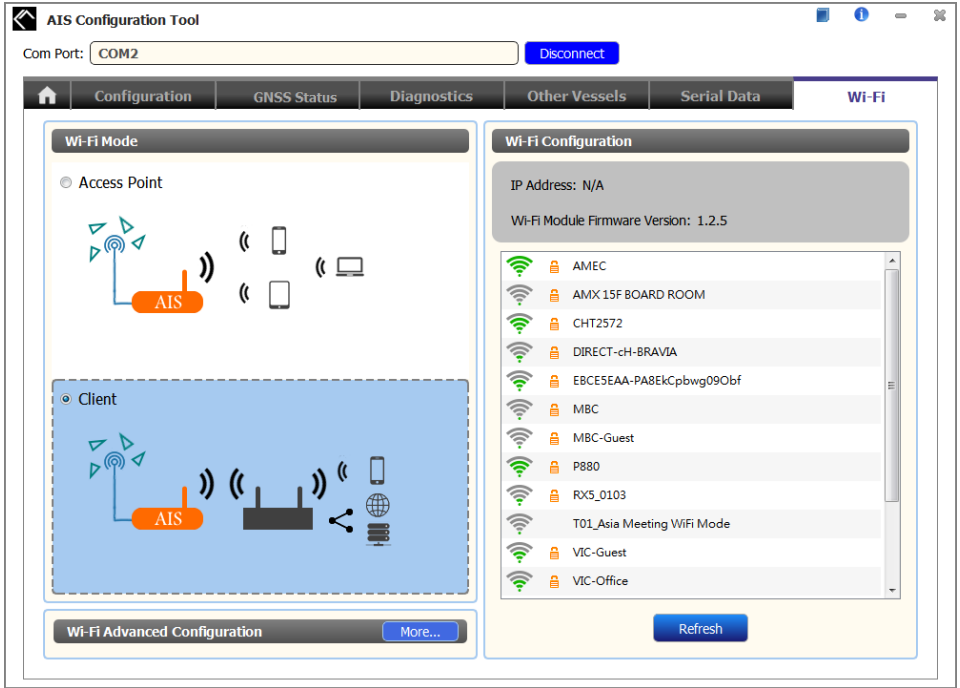

Figure 16 Client Mode

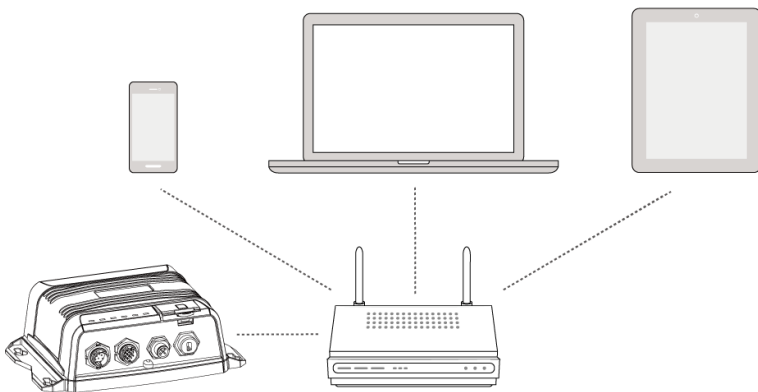

Figure 17 Join an Existing Wi-Fi Network

4.4 Built-in Integrity Test (BIIT)

With BIIT (Built in Integrity Test) function, the WideLink B600 is constantly monitoring and testing the integrity of the AIS device. Should an abnormal condition as listed below be detected, the Error LED will alert:

- MMSI not set (Error LED steady on)
- Antenna VSWR exceeding the maximum allowed level (Error LED flashing)Background noise level exceeds allowable threshold (-77dBm) (Error LED flashing)
- GPS is unable to gain lock (3D fixed) after 30 minutes of losing GPS signal (Error LED flashing)
- Unusual power input (<9V or >36V DC) or by USB power (Error LED flashing)

5 SPECIFICATIONS

5.1 Product Specifications

APPLICABLE STANDARDS	
ISO MSC. 74(69) Annex	IEC 60945 Ed. 4.0:2002
ITU-R M. 825-3:1998	IEC 61108-1 Ed. 2.0:2003
ITU-R M. 1084-5:2012	IEC 61162-1 Ed. 5.0:2016
ITU-R M. 1371-5:2014	IEC 61162-2 Ed. 1.0:1998
EN 300 440 V2.1.1	IEC 62287-2 Ed. 2.0:2017
EN 303 413 V1.1.1 (B600S)	EN 300 328 V2.1.1 (B600W)
EN 301 489-1 V2.2.0 / EN 301 489-3 V2.1.1	EN 62311:2008
EN 301 489-1 V2.2.0 / EN 301 489-17 V3.2.0 (B600W)	
EN 62368-1:2014 + A11:2017	
VHF TRANSPONDER	
Frequency Range	156.025 MHz ~ 162.025 MHz
Access Scheme	SOTDMA
Channel Bandwidth	25 KHz
Modulation	GMSK / FM
Data Rate	9,600 bps
Number of AIS Transmitter	1
Number of AIS Receiver	2 (one time-shared between AIS and DSC)
Number of DSC Receiver	1 (time-shared between AIS and DSC)
AIS Channel 1	CH 87B (161.975 MHz)
AIS Channel 2	CH 88B (162.025 MHz)
Tx Power Output	5 Watt (37 dBm \pm 1.5 dB) 1 Watt (30 dBm \pm 1.5 dB)
Rx Sensitivity	< -107 dBm @ 20% PER
Rx Message Format	AIS Class A & B messages
DSC RECEIVER	
Modulation	1,300 Hz / 2,100 Hz FSK
Data Rate	1,200 bps \pm 30 ppm
Spurious Response Rejection	\geq 70 dB for signal @ -104 dBm; BER \leq 1 %
Blocking	\geq 84 dB for signal @ -104 dBm; BER \leq 1 %
GNSS RECEIVER (INTEGRATED)	
Receiving Channels	72 channels
Accuracy	IEC 61108-1 compliant
GNSS support: GPS & GLONASS (factory default)	
POWER SUPPLY	
Supply Voltage	12V / 24V DC, 2A

Power Consumption	Typically less than 3W average @ 12V DC
CONNECTION INTERFACE	
GPS Antenna Connector	TNC (Female)
VHF Antenna Connector	SO-239 (Female)
VHF Radio Connector (B600S only)	SO-239 (Female)
FM Radio (B600S only)	SMA (Female) & dedicated cable with Motorola jack
NMEA 2000	Standard connector
NMEA 0183 (RS-422)	Support two NMEA 0183 interfaces Default baud rate 38,400 & 4,800bps Configurable and separate Tx/Rx baud rate Standard IEC 61162-1 / IEC 61162-2 sentences
Silent Mode Setting	Set by dedicated pins in the 12-pin cable
Internal Alarm Relay Setting	Set by dedicated pins in the 8-pin cable
USB	Mini-B type, waterproof
RF PERFORMANCE (B600S SPLITTER)	
Insertion loss, VHF Radio Receive path	Typical 0dB
Insertion loss, VHF Radio Transmit path	Typical 1dB
ENVIRONMENTAL	
Operating Conditions	IEC 60945 "protected" category
Operating Temperature	-15°C ~ +55°C (+5°F ~ +130°F)
Waterproof	IP67
PHYSICAL	
Width	177 mm (6.97 inches)
Height	60 mm (2.36 inches)
Depth	132 mm (5.20 inches) (exclude connector)
Weight	510 g
AMEC AIS CLASS B CONFIGURATION (PC/Mac)	
AMEC AIS Configuration Tool	www.alltekmarine.com/support/download
COMPASS SAFETY DISTANCE	
Standard Magnetic Compass	0.30m
Steering Magnetic Compass	0.30m
GA-22 GPS ANTENNA (OPTIONAL)	
Cable	Integral 10m RG-174 cable plus mounting bracket
Supply Voltage	3.3V
Wi-Fi POWER (B600W ONLY)	
Tx Transmit Power	19.53 dBm (EIRP)
Frequency Range	2412 MHz ~ 2462 MHz

5.2 Dimensions

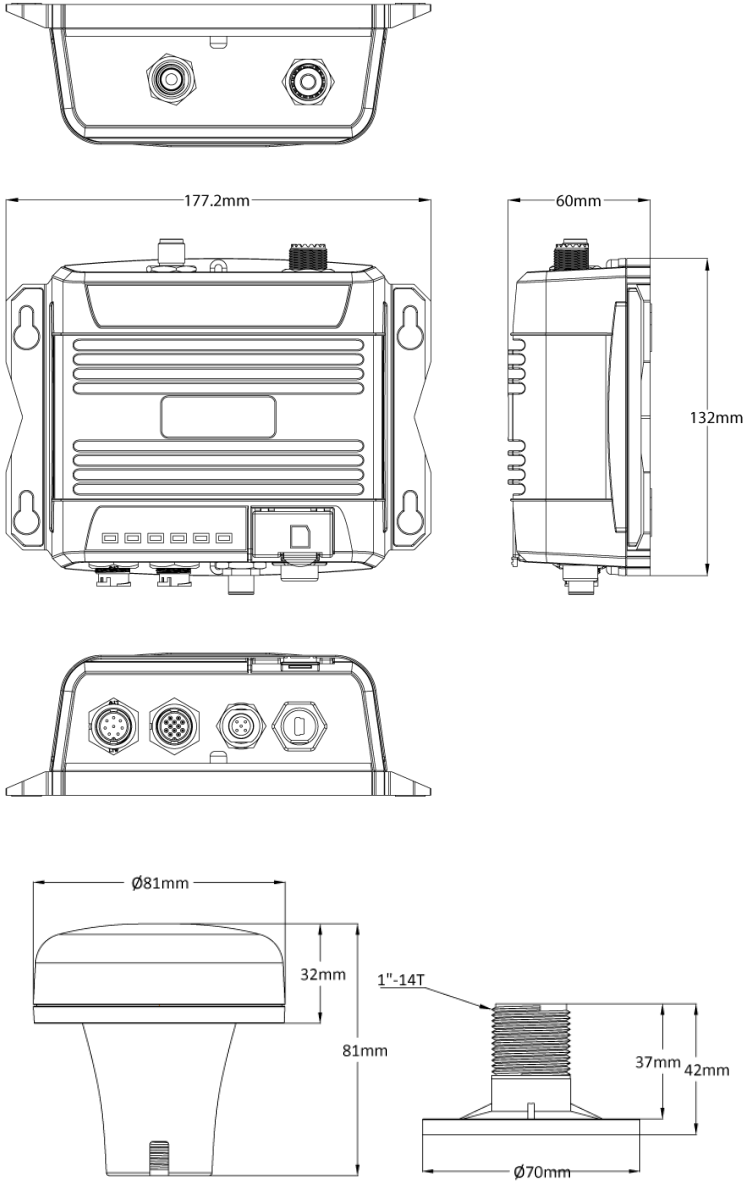

(GPS antenna is an optional item)

(Unit: mm)

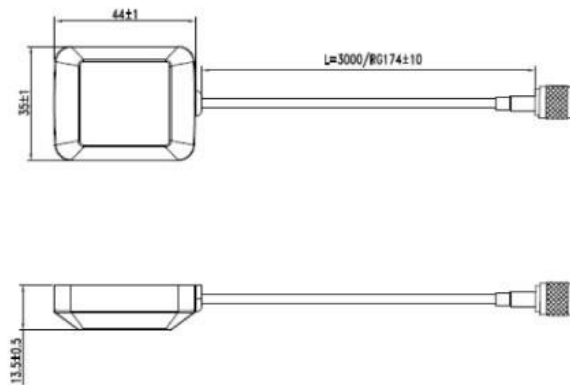

(PA-02 GPS antenna is an optional item)

5.3 Supported NMEA 2000 PGN and Translation List

PGN	Description	RX	TX	NMEA0183 TX output	NMEA0183 TX input
59392	ISO Acknowledgment		v		
59904	ISO Request	v			
60928	ISO Address Claim	v	v		
126464	PGN List - PGNs group function		v		
126993	Heartbeat		v		
126996	Product Information		v		
126998	Configuration Information		v		
127250	Vessel Heading	v	v	HDG	HDT, HDG
127258	Magnetic Variation	v		HDG	
128259	Speed, Water Referenced	v		VHW	
128267	Water Depth	v		DPT	
128275	Distance Log	v		VLW	
129025	Position, Rapid Update		v		
129026	COG & SOG, Rapid Update		v		
129029	GNSS Position Data		v		
129038	AIS Class A Position Report		v		
129039	AIS Class B Position Report		v		
129040	AIS Class B Extended Position Report		v		
129041	AIS Aids to Navigation (AtoN) Report		v		
129283	Cross Track Error	v	v	XTE	APB, RMB, XTE
129284	Navigation Data	v	v	APB, BOD, RMB	APB, BOD, BWW, RMB
129285	Navigation - Route/WP information	v	v	WPL	RMB
129539	GNSS DOPs		v		
129540	GNSS Sats in View		v		
129792	AIS DGNSS Broadcast Binary Message		v		

129793	AIS UTC and Date Report		v		
129794	AIS Class A Static and Voyage Related Data		v		
129795	AIS Addressed Binary Message		v		
129796	AIS Acknowledge		v		
129797	AIS Binary Broadcast Message		v		
129798	AIS SAR Aircraft Position Report		v		
129800	AIS UTC/Date Inquiry		v		
129801	AIS Addressed Safety Related Message		v		
129802	AIS Safety Related Broadcast Message		v		
129803	AIS Interrogation		v		
129804	AIS Assignment Mode Command		v		
129805	AIS Data Link Management Message		v		
129806	AIS Channel Management		v		
129807	AIS Group Assignment		v		
129809	AIS Class B "CS" Static Data Report, Part A		v		
129810	AIS Class B "CS" Static Data Report, Part B		v		
129811	AIS Single Slot Binary Message		v		
129812	AIS Multi Slot Binary Message		v		
129813	AIS Long-Range Broadcast Message		v		
130306	Wind Data	v		MWD, MWV	
130310	Environmental Parameters	v		MTW	
130311	Environmental Parameters	v		MTW	
130312	Temperature	v		MTW	
130314	Actual Pressure	v		XDR, MDA	
130316	Temperature, Extended Range	v		MTW	

5.4 Supported NMEA 0183 Sentences

Output Sentences	
Sentence	Description
ABK	AIS addressed and binary broadcast acknowledgement
ACA	AIS channel assignment message
ALR	Set alarm state
GGA	Global positioning system (GPS) fix data
GSA	GNSS DOP and active satellites
GSV	GNSS satellites in view
RMC	Recommended minimum specific GNSS data
TXT	Text transmission
VDM	AIS VHF data-link message
VDO	AIS VHF data-link own-vessel report
Input Sentences	
Sentence	Description
ABM	AIS addressed binary and safety related message
ACK	Acknowledge alarm
AIQ	Query Sentence
BBM	AIS broadcast binary message
EPV	Command or report equipment property value
HDT	Heading true
SSD	AIS ship static data
THS	True heading and status
VSD	AIS voyage static data

6 TROUBLESHOOTING

The transmitting LED (Green color) is not illuminated, why?

- The Class B device requires GPS information from GPS antenna before making AIS transmission. Please check if your GPS antenna is connected correctly. The Tx LED will flash orange every 5 seconds meaning that the device is still acquiring a GPS fix and therefore not ready yet to make transmission.
- For each transmission, the Tx LED indicator will flash once quickly. The green light from the Tx LED could be missed if not observed carefully.

WideLink B600 receives AIS signals normally, but no one in the surrounding can see me, why?

- VHF antennas interference: if you are using a dedicated AIS/VHF antenna for your transponder, be sure that it is placed following the instructions in chapter 2.3. In several tests, mounting two VHF antennas next to another typically reduces the transmitting range to both antennas by 50-70%.
- GPS is not fixed: If your GPS antenna is not connected or setup correctly, your transponder will see other vessels fine, but you will not be sending out your vessel position. The Tx LED will flash orange every 5 seconds meaning that the transponder is still acquiring a GPS fix and therefore not ready yet to make transmission.
- The location of VHF antenna is directly related to AIS transmitting range. The VHF antenna should be installed at mast as high as possible.

No data is being received by chart plotter, why?

- Please check that the power supply is connected correctly at WideLink B600.
- Please check that the power supply is 12V or 24V with sufficient current capacity (no less than 2A).
- Please make sure that the connections between WideLink B600 to the chart plotter are correct.

My MMSI is being received by other vessels but my vessel name is not shown on their chart plotter or PC, why?

- Older software and AIS displays may not be fully compatible with Class B transponders. In some of these cases, older equipment might only have Class B vessel show up on their displays with just MMSI number without the vessel name. This is usually due to the receiving device not knowing how to process the Message 24 static data from Class B transponders. Please contact the chart plotter maker and ask for software upgrades (for these older chart plotters) to resolve this issue.

The Red Error LED indication at WideLink B600 is illuminated, why?

- The unit may not have a valid MMSI. Please check if the AIS transponder is correctly entered with a valid MMSI.

- Please make sure that both VHF and GPS antennas and their cables are working properly and not damaged.
- Return the unit to your dealer/service partner for technical check.

Why is the Wi-Fi signal weak and how can I improve it?

- The router is too far from the client devices. To improve the Wi-Fi signal strength reallocated the device to a more central location.
- There might be intervening barriers (e.g. a large expanse of metal) that are blocking the Wi-Fi signals. Relocated the device to the center of the area where the client devices are placed, or to a position where the router and the devices are within a visible distance without interfering barrier.
- Nearby devices (e.g. microwaves/wireless phones) using the same frequency band may interfere with the router's 2.4GHz Wi-Fi transmission. To improve the Wi-Fi signal strength, try to avoid channel overlapping by reassigning their operation channels to channels 1, 6 or 11.

If you still encounter difficulties to set up or operate WideLink B600 correctly, please email to service@alltekmarine.com for further instructions.

7 ABBREVIATIONS

AIS	Automatic Identification System
COG	Course Over Ground
CPA	Distance to Closest Point of Approach
CSTDMA	Carrier-Sense Time Division Multiple Access
SOTDMA	Self-Organized Time Division Multiple Access
DSC	Digital Selective Calling
ECS	Electronic Chart System
ETA	Estimated Time of Arrival
GPS	Global Positioning System
IMO	International Maritime Organization
MMSI	Maritime Mobile Service Identity
SOG	Speed Over Ground
TCPA	Time to Closest Point of Approach
TDMA	Time Division Multiple Access
UTC	Coordinated Universal Time
VHF	Very High Frequency
VTS	Vessel Traffic Services

8 FCC INTERFERENCE STATEMENT

NOTE: This equipment has been tested and found to comply with the limits for a Class A digital device, pursuant to part 15 of the FCC Rules. These limits are designed to provide reasonable protection against harmful interference when the equipment is operated in a commercial environment. This equipment generates, uses, and can radiate radio frequency energy and, if not installed and used in accordance with the instruction manual, may cause harmful interference to radio communications. Operation of this equipment in a residential area is likely to cause harmful interference in which case the user will be required to correct the interference at his own expense.

This device complies with Part 15 of the FCC Rules. Operation is subject to the following two conditions:

- 1) This device may not cause harmful interference, and
- 2) This device must accept any interference received, including interference that may cause undesired operation.

Any changes or modifications not expressly approved by AMEC for compliance could void of the user's authority to operate the equipment.

9 RF Exposure Warning

WARNING: This device generates and radiates RF electromagnetic energy and must be installed and operated according to the instructions contained in this manual. Failure to do so may result in product malfunction and/or exposure to potentially harmful levels of radio frequency radiation.

WARNING: Never operate this device unless it is properly connected to a VHF antenna. To maximize performance and minimize human exposure to RF energy, always mount the antenna at least 3m from the device.

The system has a Maximum Permissible Exposure (MPE) radius of 1.2m from the antenna, and 20cm from Wi-Fi antenna (B600W only). This has been determined assuming the maximum power of the transmitter and using a standard half-wave monopole VHF antenna with a maximum gain of 3dBi and termination impedance of 50 ohms.

When installing the antenna and operating the equipment consider the following:

- The antenna should be mounted at a minimum vertical distance of 5m above the deck in order to meet international safety directives on Maximum Permissible Exposure (MPE). Failure to adhere to these limits could expose persons within the radius to RF radiation in excess of the recommended MPE limits.
- Higher gain VHF antennas will require a larger MPE radius.
- Do not operate the unit when anyone is within the MPE radius of the antenna.
- The antenna should not be co-located or operated in conjunction with any other transmitting antenna.

DECLARATION OF CONFORMITY

Hereby, Alltek Marine Electronics Corp. (AMEC) declares that this WideLink B600/B600W is in compliance with the essential requirements and other relevant provisions of Directive **2014/53/EU RED**.

A copy of the Declaration of Conformity can be obtained on-line from under “Download”:
http://www.alltekmarine.com/products_detail.php?bgid=3&gid=53

INDUSTRY CANADA NOTICE

This AIS class B digital device complies with Canadian ICES-003.
Cet dispositif numérique de la AIS classe B est conforme à la norme NMB-003 du Canada.

AMEC WORLDWIDE WARRANTY

Limited warranty

Subject to the terms, conditions and limitations set forth in this Worldwide Limited Warranty (hereinafter the “Warranty”), AMEC warrants that its products, when properly installed and used, will be free from defects in material and workmanship for a period of twelve (12) months, from the date of first purchase (the ‘Warranty Period’)

For the purposes of this warranty, ‘date of first purchase’ means the date that the product was purchased by the first retail customer, or by the institutional customer, or in the case of a product installed on a new vessel or any other marine related platform by a certified AMEC original equipment manufacturer (a ‘AMEC OEM’), the date that such vessel was purchased by the first retail customer.

AMEC will, at its sole option, repair or replace any defective products or components returned during the Warranty Period in accordance with the terms, conditions and limitations set forth below. Such repairs or replacement will be the sole remedy of the customer under this Warranty.

Standard Warranty Service

To qualify for standard warranty service the product must be returned to a AMEC-certified service agent (i) within the Warranty Period, and (ii) within thirty (30) days of the alleged product failure. Any products returned must be securely packaged and sent pre-paid and insured to AMEC or to a AMEC-certified service agent. All products returned must be accompanied by a copy of the original sales receipt to be eligible for standard warranty service.

Other conditions

This Warranty is fully transferable provided that you furnish the original proof of purchase to the AMEC -certified service agent. This Warranty is void if the seal label is removed or defaced.

THE LIABILITY OF AMEC TO A CUSTOMER UNDER THIS WARRANTY, WHETHER FOR BREACH OF CONTRACT, TORT, BREACH OF STATUTORY DUTY OR OTHERWISE SHALL IN NO EVENT EXCEED AN AMOUNT EQUAL TO THE TOTAL PURCHASE PRICE OF THE PRODUCT GIVING RISE TO SUCH LIABILITY AND IN NO EVENT SHALL AMEC BE LIABLE FOR SPECIAL, INCIDENTAL, CONSEQUENTIAL OR INDIRECT DAMAGES OR LOST OF GOODWILL, REPUTATION, LOSS OF OPPORTUNITY OR INFORMATION, DATA, SOFTWARE OR APPLICATIONS.

In the event that any term or provision contained in this Warranty is found to be invalid, illegal or unenforceable by a court of competent jurisdiction, then such provision shall be deemed modified to the extent necessary to make such provision enforceable by such court, taking into account the intent of the parties. All AMEC products sold or provided hereunder are merely aids to navigation. It is the responsibility of the user to exercise discretion and proper navigational skill independent of any AMEC product.

Appendix: How to Determine Serial Port

If your PC/laptop does not have an available serial port, you may use an RS232-to-USB adapter. To find out the proper serial port for connection, use the following instructions.

Windows 10 & Windows 11

Windows button + S and type Device Manager in the search box, then select Device Manager from the list of results. Expand the Ports (COM & LPT) and port number are presented with a numerical number within a parenthesis in the following format (COMXX).

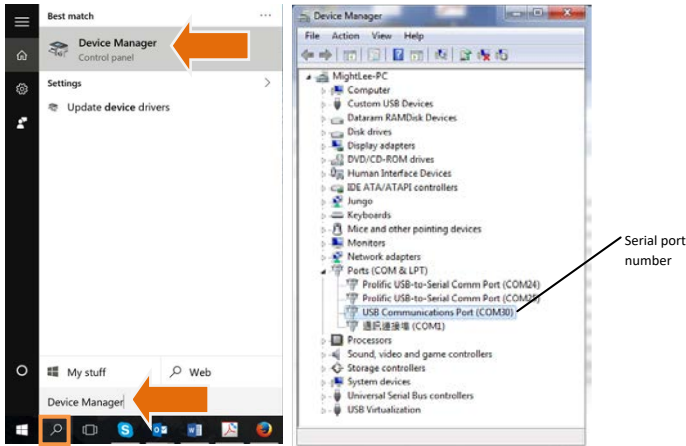

Alltek Marine Electronics Corporation

14F-2, No. 237, Sec. 1, Datong Rd.,
Xizhi Dist., New Taipei City, 22161, Taiwan

Tel: +886 2 8691 8568

Fax: +886 2 8691 9569

Email: service@alltekmarine.com

Website: www.alltekmarine.com