



P200

→ AIS Class B with Display ←

↑
USER MANUAL



Automatic Identification System

FOREWORD

We thank you for the purchase of your new P200 AIS Class B with Display. Wherever you sail now, you can have a better overview of your surroundings at sea and voyage with more safety.

P200 is strictly tested to meet the rigorous demands of the marine environment. With proper installation and use, the equipment will serve loyally and reliably at its optimum.

For sales, services, and technical supports, please contact your local AMEC representatives or Alltek Marine Electronics Corp. at sales@alltekmarine.com or service@alltekmarine.com You are always welcome to visit our website at www.alltekmarine.com for new product status and company update.

Thank you again. Be safe.

COPYRIGHT

The entire contents of this instruction manual, including any future updates, revisions, and modifications, shall remain the property of AMEC at all times. Unauthorized copies or reproduction of this manual, either in part or whole, in any form of print and electronic media, is prohibited. The contents herein can only be used for the intended purpose of this manual.

DISCLAIMER

AMEC is devoted to maintaining the correctness of this product manual. As we continue to improve our AIS products to satisfy all customers' needs, information in this document is subject to change without notice. AMEC does not make any representations or warranties (implied or otherwise) regarding the accuracy and completeness of this document and shall in no event be liable for any loss of profit or any commercial damage, including but not limited to special, incidental, consequential, or other damage.

WARNING!

WARNING: The device must be installed and configured in conformity with the provided instructions in the manual by qualified installer in order to ensure the device performance.

WARNING: It is the responsibility of the operator to handle the AIS device with care. The device cannot replace human vigilance. Therefore it is important to keep a diligent outlook at all times.

WARNING: Please bear in mind that not all vessels are equipped with AIS transceivers and therefore may not be visible to this device. Likewise, certain conditions, such as device malfunction, the environment, improper use, and overcrowded port traffic, may exist whereby the vessel equipped with this AIS device is not visible to other AIS transceivers.

WARNING: DO NOT DISASSEMBLE OR MODIFY THE EQUIPMENT. Improper disassembly or modification could impair its performance and will invalidate the guarantee.

FOR USERS IN THE UNITED STATES OF AMERICA ONLY

WARNING: It is a violation of the rules of the Federal Communications Commission to input an MMSI that has not been properly assigned to the end user, or to otherwise input any inaccurate data in this device.

★ The entry of static data into this device shall be performed by the vendor of the device or by an appropriately qualified person in the business of installing marine communications equipment on board vessels.

★ Instructions on how to accurately enter and confirm static data in the device can be found in this user manual.

TABLE OF CONTENT

1	INTRODUCTION	7
1.1	DEVICE OVERVIEW	7
1.2	ABOUT AIS	9
1.2.1	What is AIS?	9
1.2.2	AIS Class A vs. SOTDMA Class B vs. CSTDMA Class B	10
1.2.3	AIS Message	11
1.2.4	AIS Transmit Rate	12
2	INSTALLATION	13
2.1	EQUIPMENT IN THE BOX	13
2.2	CONNECTION DIAGRAM	14
2.3	INSTALLATION PROCEDURES	15
2.4	DEVICE (MAIN UNIT) INSTALLATION	16
2.4.1	Table Mounting	16
2.4.2	Flush Mounting	18
2.5	VHF ANTENNA INSTALLATION	19
2.6	GPS ANTENNA INSTALLATION	20
2.7	CABLE CONNECTION	21
2.7.1	Connection with VHF Antenna	21
2.7.2	Connection with GPS Antenna	22
2.7.3	Connection with Power Supply	22
2.7.4	Connection with NMEA 0183	23
2.7.5	Connection with NMEA 2000	24
2.7.6	Connection with Ethernet (Optional)	24
3	OPERATION	25
3.1	CHART DISPLAY AND CONTROLS	25
3.2	TURNING THE AIS TRANSCEIVER ON	26
3.2.1	Setup Wizard	27
3.3	ON-SCREEN INFORMATION	30
3.4	CHART	32
3.5	PLOT VIEW	34
3.6	TARGETS	35
3.6.1	Friend Ships	36
3.7	ALARMS	39
3.8	MESSAGES	41
3.9	OPTIONS	42
3.9.1	Options→General→User Settings	43
3.9.2	Options→General→Alarm Settings	44
3.9.3	Options→General→Log	45
3.9.4	Options→Vessel Data Settings	45
3.9.5	Options→NMEA 0183 Settings	46
3.9.6	Options→Maintenance	46
3.9.7	Options→Advanced	46
3.10	FUNCTION KEY (FN) OPERATION	47
3.10.1	Go to Own Vessel	47
3.10.2	Man Overboard (MOB) Activation	48

3.11	DEVICE INFORMATION	49
3.11.1	GNSS Status	50
3.11.2	Information.....	51
3.11.3	Help	53
4	SPECIFICATIONS.....	54
4.1	PRODUCT SPECIFICATIONS	54
4.2	DIMENSIONS	56
4.3	SUPPORTED NMEA 0183 SENTENCES.....	57
4.4	NMEA 2000 PGN INFORMATION	58
5	TROUBLESHOOTING	59
6	ABBREVIATIONS.....	61
	FCC INTERFERENCE STATEMENT	62
	RF EXPOSURE WARNING	63
	DECLARATION OF CONFORMITY	64
	INDUSTRY CANADA NOTICE.....	64
	AMEC WORLDWIDE WARRANTY.....	65

1 INTRODUCTION

1.1 Device Overview

The P200 contains a robust and powerful AIS Class B transceiver with display for enhanced situational awareness and intuitive navigation.

P200 offers two product options: 1) model P200-CS supports CSTDMA-type AIS Class B function; 2) model P200-SO supports SOTDMA-type AIS Class B function.

Multiple tools including alarms, messages, CPA/TCPA notify users of hazards and potential problems, provided in real time by P200's advanced processing unit. Its GNSS positioning engine delivers high sensitivity and minimal acquisition times, displaying dynamic vessel data on screen for instant access. P200 supports AIS messages with an intuitive interface ensuring messages can be read and composed with least efforts.

The device can be controlled by both touchscreen and keypad to ensure operational efficiency and reliability. The advanced user-interface enables a smooth operation to access key information on screen. Basic C-MAP global base map is built in with advanced 4D chart supported as option.

The high brightness range of the display screen makes it readable from less ambient light to under sunlight. It's designed to survive rough marine environment with its IPX7 water resistance performance. Sensors and instruments can be easily connected through its NMEA 2000, NMEA 0183 or optional Ethernet interfaces.

Device Front View

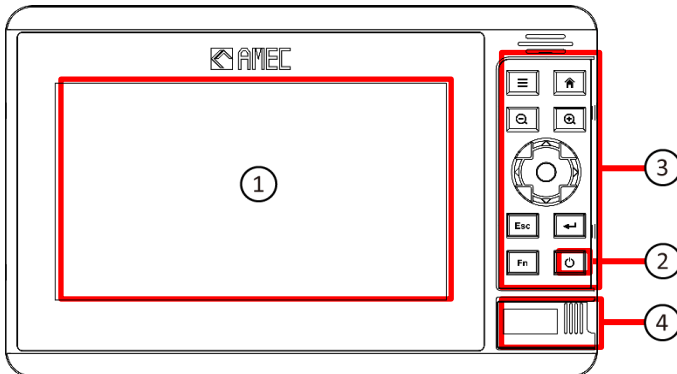

Item No.	NAME
1	Touchscreen
2	Power on/off key
3	Keypad
4	Two microSD card slots. The max. card size is 32 GB.

Device Rear View

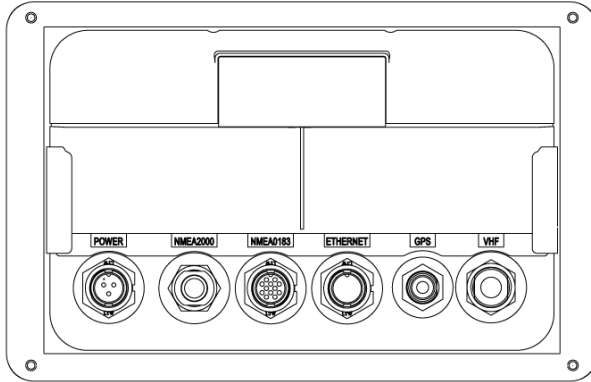

NAME	DESCRIPTION	TYPE OF CONNECTOR
POWER	Power in, 12V / 24V DC	Round type, 3 pins
NMEA2000	NMEA 2000 (CAN bus) connector	5 pins, standard connector LEN=1
NMEA0183	NMEA 0183 (RS-422) connector	12 pins (4 pins are reserved)
Ethernet (OPTIONAL)	Ethernet connector (OPTIONAL)	8 pins (with a cable connecting to RJ45 connector)
GPS	GPS antenna connector	TNC (female)
VHF	VHF antenna connector	SO-239 (female)

1.2 About AIS

1.2.1 What is AIS?

The Automatic Identification System (AIS) is a Very High Frequency (VHF) radio broadcasting system that transfers packets of data over the VHF data link (VDL) and enables AIS equipped vessels and shore-based stations to exchange identification information and navigational data. Ships with AIS transceivers continually transmit their ID, position, course, speed and other data to all nearby ships and shore stations. Such information can aid greatly in situational awareness and provide a means to assist in collision avoidance.

AIS equipment is standardized by ITU, IEC, IALA and IMO and is subject to approval by a certification body. The following AIS devices have been developed for variant applications.

- **AIS Class A:**
mandated by the IMO for vessels of 300 gross tonnages and upwards engaged on international voyages, cargo ships of 500 gross tonnages and upwards, as well as passenger ships. It transmits typically on 12.5 watt output power.
- **AIS Class B:**
provides limited functionality and is intended for non-SOLAS commercial vessels and recreational vessels. It transmits typically on 2 watt output power.
- **AIS Receiver:**
only receives AIS signal and it does not have transmitter to send out AIS signal. Suitable for recreational vessel that does not want to send out its vessel information.
- **AIS Base Station:**
is provided by aids-to-navigation authorities to enable the ship to shore / shore to ship transmission of information. Networked AIS Base Stations can assist in providing overall maritime domain awareness.
- **AIS AtoN (Aids to Navigation):**
provides an opportunity to transmit position and status of buoys and lights through the same VDL, which can then show up on AIS-ready devices within the range.
- **AIS SART:**

Search and Rescue Transmitter using AIS can be used to assist in determining the location of a vessel in distress. It is typically used on life rafts.

■ **AIS on Search and Rescue (SAR) Aircraft:**

used on airplanes and helicopters to assist search and rescue operation.

1.2.2 AIS Class A vs. SOTDMA Class B vs. CSTDMA Class B

A brief comparison between class A and class B AIS is illustrated in the following table. P200-SO is an SOTDMA-type class B AIS transponder, P200-CS is a CSTDMA-type class B AIS transponder.

Type of AIS	Class A	Class B-SO	Class B-CS
Transmit Power	12.5W	5W	2W
Transmit Rate	Up to every 2~3 second	Up to every 5 seconds	Every 30 seconds
AIS Data Presented	Static, Dynamic, Voyage	Static, Dynamic	Static, Dynamic
Access Scheme Technology	SOTDMA (Self-organizing)	SOTDMA (Self-organizing)	CSTDMA (Carrier-sense)
Min. Keyboard & Display (MKD)	Yes	No	No
Guaranteed Time Slot Allocation	Yes	Yes	No
External GPS Connection	Yes	No	No
Applicable Standard	IEC 61993-2	IEC 62287-2	IEC 62287-1
IMO Mandate	Mandatory for all SOLAS vessels	No mandate	No mandate
Applications	Commercial vessels, fishing boats, working boats, passenger boats with more than 12 passengers	Smaller commercial, fishing and work boats, recreational vessels	Recreational vessels and small fishing boats

1.2.3 AIS Message

P200 exchanges the following navigational data with other AIS equipped vessels within VHF range to increase the safety of your journey at sea:

- **Static data:**
 - MMSI
 - Vessel name
 - Vessel call sign
 - Type of ship
 - Ship dimensions / GPS antenna location
- **Dynamic data:**
 - Position of the vessel
 - Course over ground (COG)
 - Speed over ground (SOG)
 - True heading

P200 transceiver receives also safety related messages (SRM) from other vessels or persons who are in distress.

1.2.4 AIS Transmit Rate

P200-CS (CSTDMA Class B AIS) broadcasts ship dynamic data per following reporting interval. Besides, ship static data will be broadcasted every 6 minutes.

Ship Condition	Nominal Reporting Interval
Ship not moving faster than 2 knots	3 minutes
Ship moving faster than 2 knots	30 seconds

P200-SO (SOTDMA Class B AIS) also broadcasts ship's static data every 6 minutes. Yet, its ship dynamic data will be transmitted per following reporting interval:

Ship Speed	Nominal Reporting Interval	Increased Reporting Interval
>23 knots	Every 5 seconds	Every 15 seconds
between 14-23 knots	Every 15 seconds	Every 30 seconds
between 2-14 knots	Every 30 seconds	Every 30 seconds
≤ 2 knots or at anchored or moored	Every 3 minutes	Every 3 minutes

The Class B "SO" AIS follows the rules set by ITU-R M.1371-5, and increases the reporting interval to "Increased Reporting Interval" in accordance with Table above when less than 50 % of the AIS-signal-slots of each of the last four consecutive frames are free. When more than 65 % of the slots of each of the last four consecutive frames are free, the Class B "SO" AIS reports at the "Nominal Reporting Interval".

2 INSTALLATION

2.1 Equipment in the Box

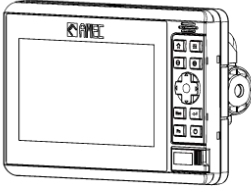

AIS Class B with display



3-pin power cable 2m



12-pin NMEA0183 cable 2m

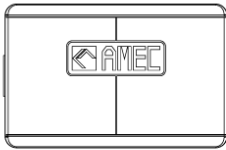

Sun cover



U-shaped mounting bracket kit

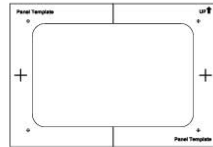

Panel mount cutting template



Software CD: configuration utility, USB driver, AIS Viewer, user manual



User manual



TP3.5x32 screws

Optional Accessory

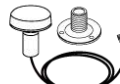

GPS antenna GA-22 with 10m cable



8-pin Ethernet cable (RJ-45 female)

2.2 Connection Diagram

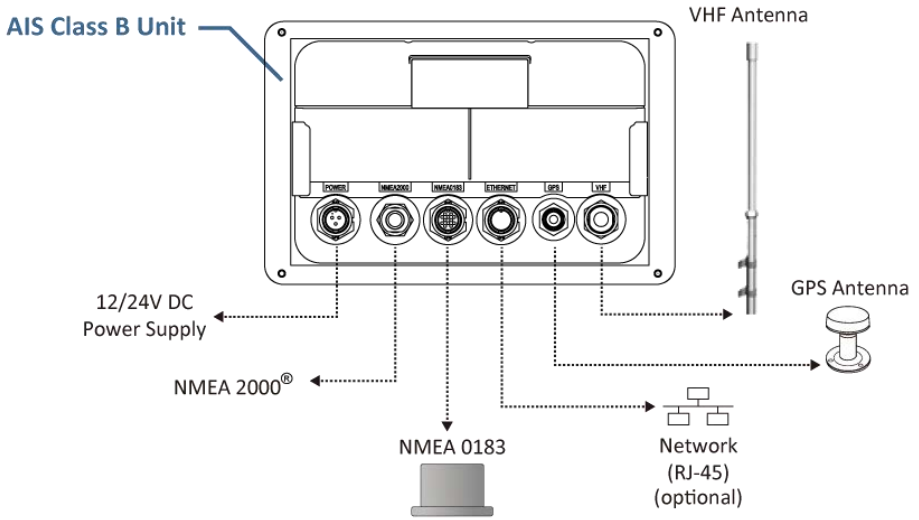

Note: The Ethernet connector is not included in the standard model.

2.3 Installation Procedures

Please familiarize the manual content before begin installation. Depending on your hardware configuration, use the following recommended steps for installation.

- 1) Mount the AIS Class B unit to an appropriate location (either table mount or panel mount referring to following sections)
- 2) Install VHF antenna
- 3) Install GPS antenna
- 4) Connect antenna cables to the transceiver
- 5) Connect to other devices via NMEA 0183 or NMEA 2000 interface if applicable
- 6) Connect to an appropriate power source (12V / 24V DC)
- 7) Power on the power source (which turns on the transceiver unit)
- 8) Program MMSI and vessel information into the device
- 9) Perform system functional test

2.4 Device (Main Unit) Installation

2.4.1 Table Mounting

- 1) Place the mounting bracket to the location where the AIS unit is to be installed.
- 2) Fix the bracket with five (5) tapping screws.
- 3) Install the AIS unit into the bracket hook.
- 4) Fix the AIS unit with the two fixing knobs as supplied in the package.

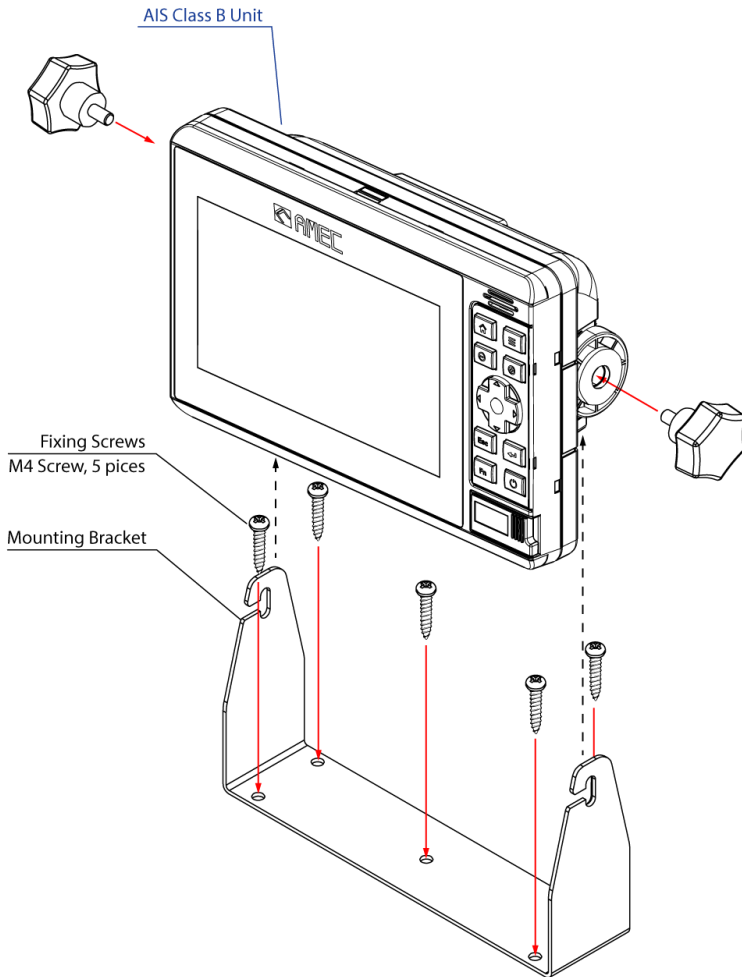

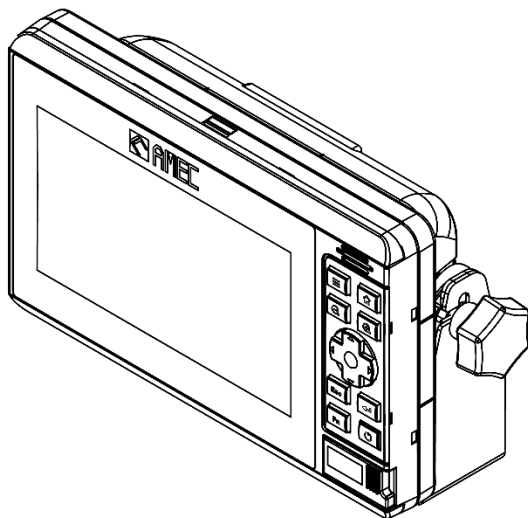

2.4.2 Flush Mounting

- 1) Make a rectangle hole at the location to be installed, using the panel mount cutting template.
- 2) Remove the two (2) plastic screw covers which are fitted on the top and bottom sides of the display front face.
- 3) Confirm whether the AIS unit and the rectangular hole meet or not. Correct the rectangular hole if it is defective.
- 4) Put the AIS unit on the opening and fix with four (4) tapping screws.
- 5) Refit the plastic covers removed in step (2).

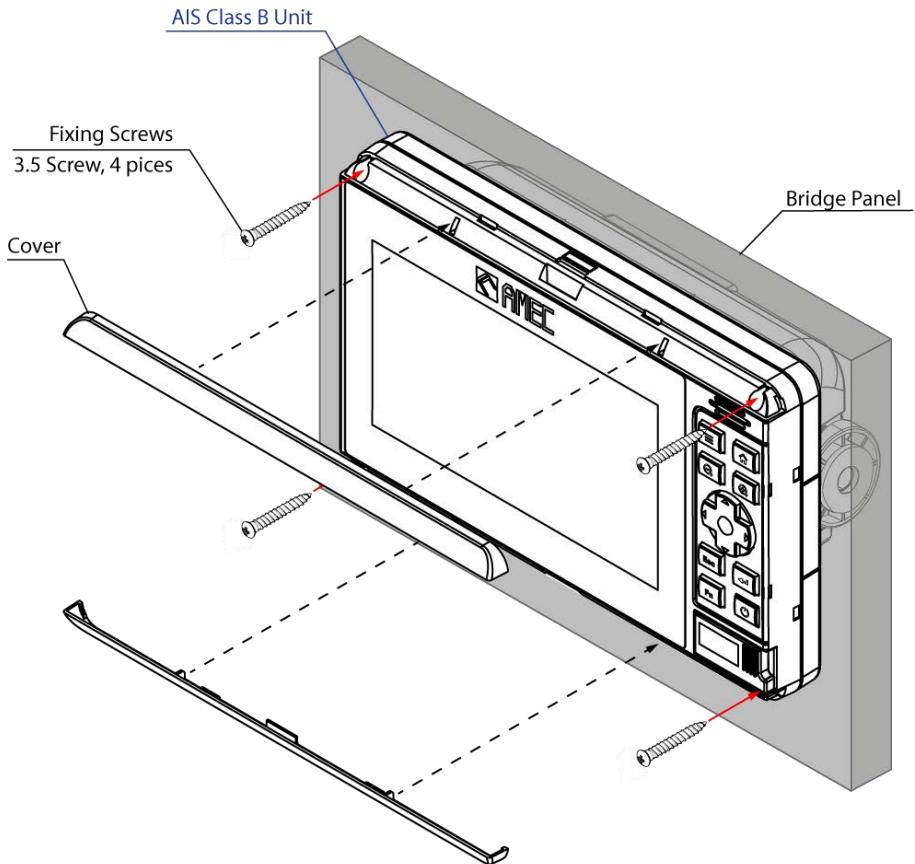

2.5 VHF Antenna Installation

The quality and positioning of the antenna are the most important factors dictating AIS performance. It is recommended that a VHF antenna with omnidirectional vertical polarization be specifically tuned for marine band. Since the range of VHF signals is largely decided by line of sight distance, the VHF antenna should be placed as high as possible and at least 5 meters away from any constructions made of conductive materials.

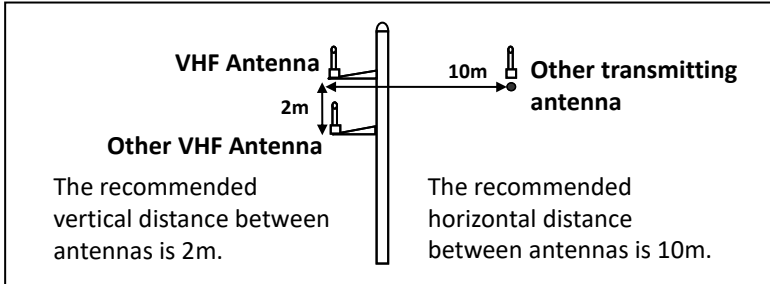

VHF Antenna Locations

The VHF antenna connector type on P200 is SO239 which is designed to work with a PL259 connector.

2.6 GPS Antenna Installation

Install the GPS antenna where it has a clear view to the sky, so that it may access the horizon freely with 360° degrees.

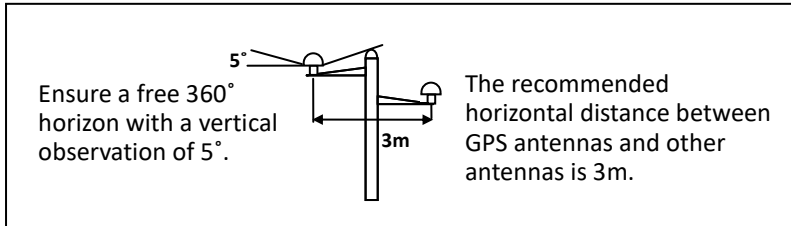

GPS Antenna Locations

It is recommended to keep the GPS antenna out of the transmitting beam of high-power transmitters such as Inmarsat devices and radar.

When connecting the cables, take note of the following precautions.

- Bending cables may cause damages to the inner wires and impair overall the performances.
- Each coaxial cable should be set up separately and can only be set up in a single cable tube.
- Insulation on connector port of the coaxial cable should be considered.

P200 is tested and certified with the GPS antenna GA-22. It's recommended to use GA-22 with P200 to ensure optimal reliability of your AIS system.

2.7 Cable Connection

2.7.1 Connection with VHF Antenna

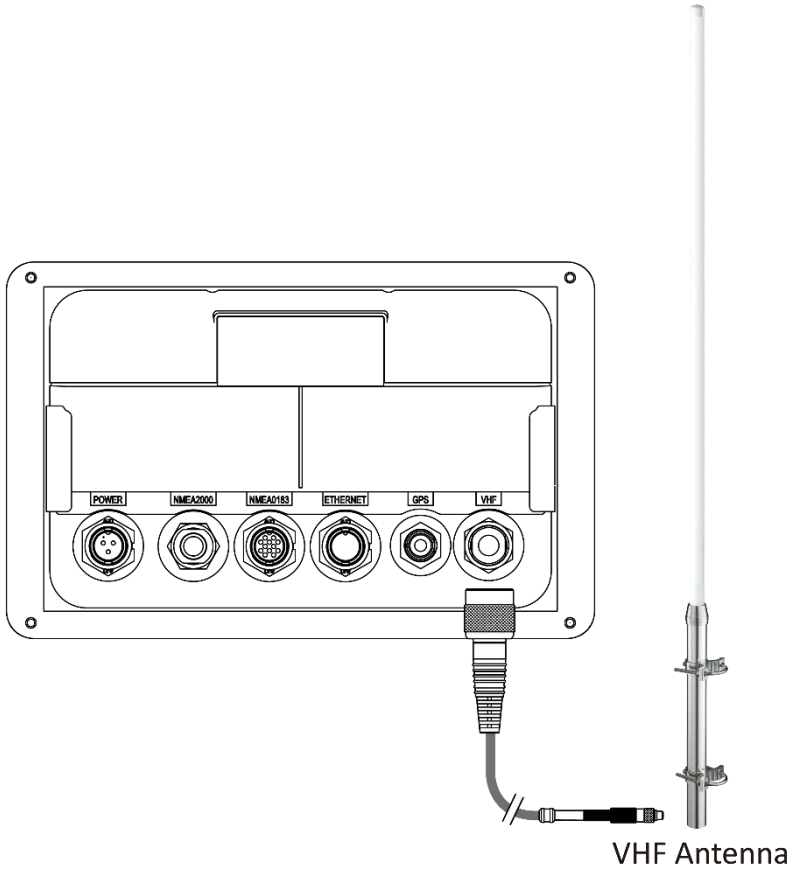

Note: The VHF antenna and cable is not included in the standard supply.

2.7.2 Connection with GPS Antenna

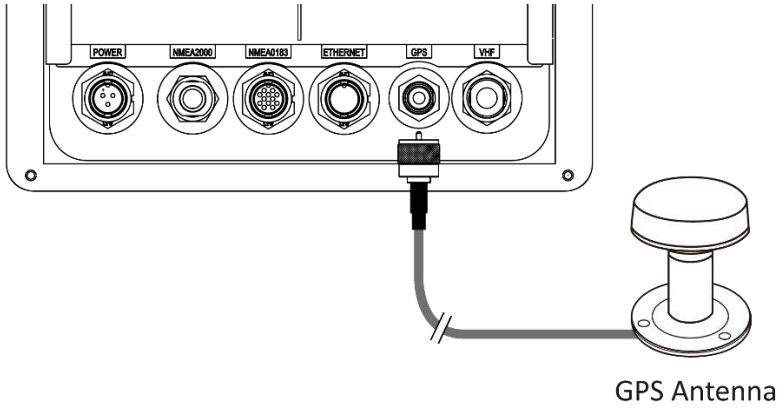

Note: The GPS antenna and cable is not included in the standard supply.

2.7.3 Connection with Power Supply

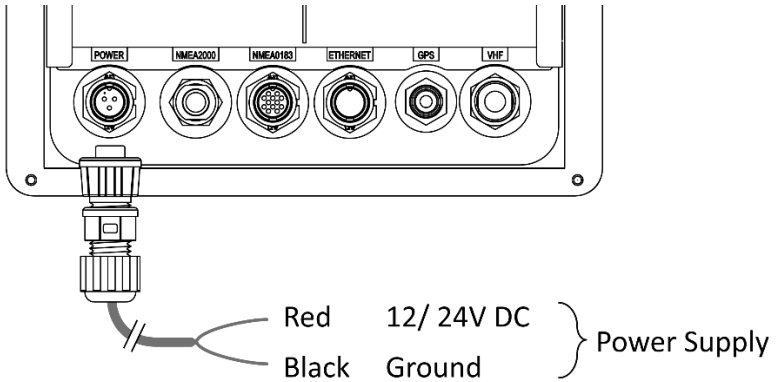

2.7.4 Connection with NMEA 0183

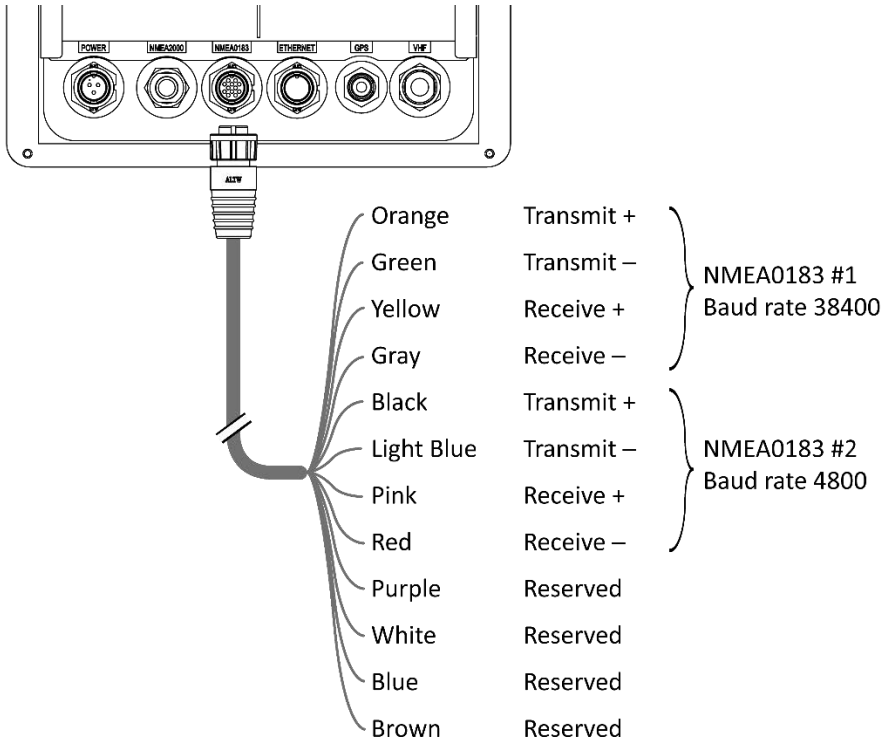

2.7.5 Connection with NMEA 2000

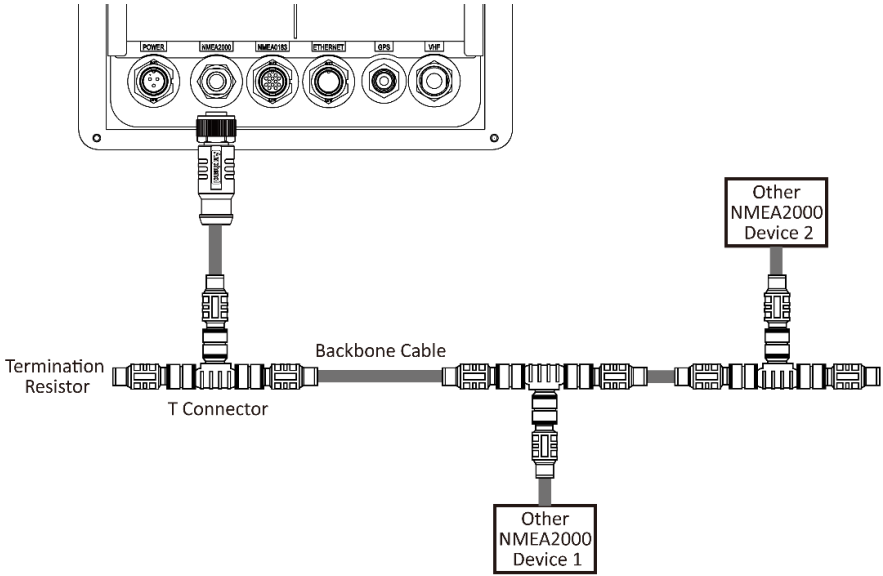

Note: The NMEA 2000 T-connector and cable is not included in the standard supply.

2.7.6 Connection with Ethernet (Optional)

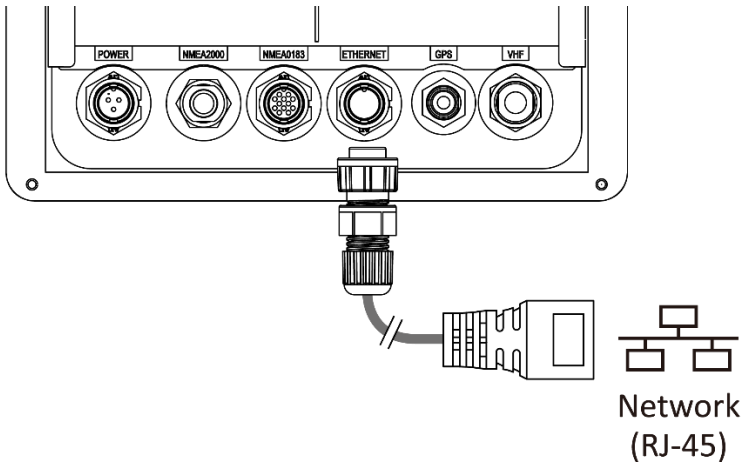

3 OPERATION

3.1 Chart Display and Controls

P200 is designed to operate in an intuitive way. All the functions can be served either by touch screen or with buttons.

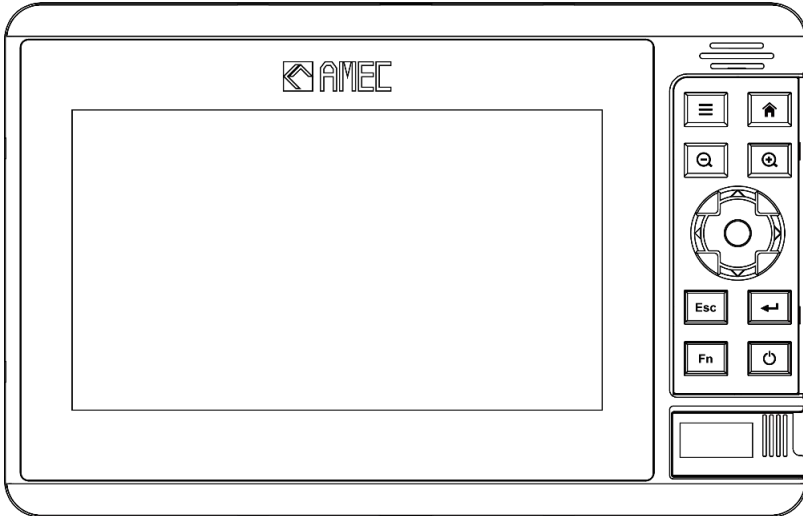

Function	Description
Touchscreen	The touchscreen can be used to control the AIS Class B with Display
Buzzer	The buzzer can provide an audible sound when a key is pressed, a message is received, or an alarm is activated.
Menu	Press to open or close menu
Home	Press to display the Homescreen
Zoom-In	for adjusting the range in chart applications
Zoom-Out	for adjusting the range in chart applications
Arrow Key	up, down, left, right to move the cursor on the chart or maneuver through the navigate the menu tree
ESC	Press to return to the previous menu or dialog
Enter	Press to confirm a selection
Fn	Function key: go to own vessel or create MOB waypoint
Power	Press to power on or off the device. The button provides also a shortcut to adjust brightness and activate night mode
MicroSD card reader	MicroSD card slots *2

3.2 Turning the AIS Transceiver on

Once P200 is connected to a power supply, press the power button and the AIS transceiver will start immediately.

User will be asked to read and agree the End User License Agreement (EULA).

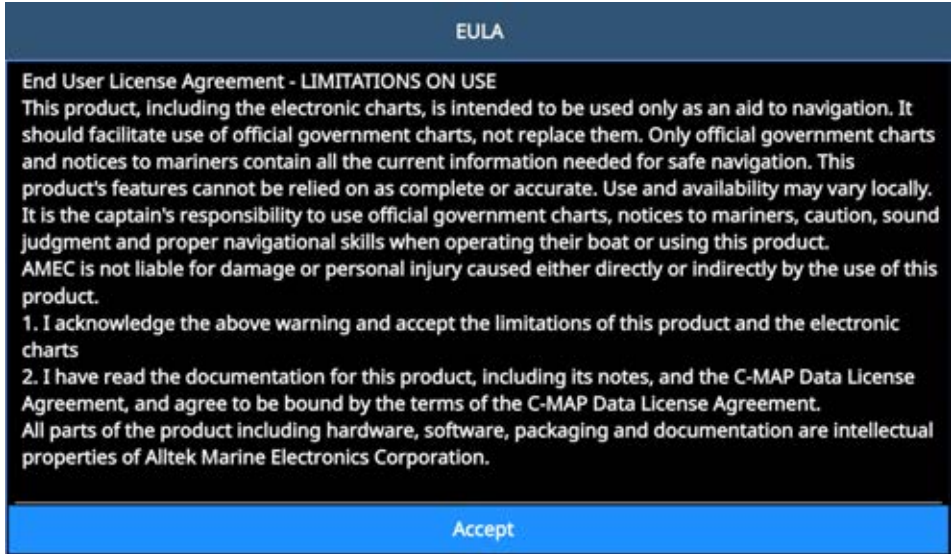

EULA

End User License Agreement - LIMITATIONS ON USE

This product, including the electronic charts, is intended to be used only as an aid to navigation. It should facilitate use of official government charts, not replace them. Only official government charts and notices to mariners contain all the current information needed for safe navigation. This product's features cannot be relied on as complete or accurate. Use and availability may vary locally. It is the captain's responsibility to use official government charts, notices to mariners, caution, sound judgment and proper navigational skills when operating their boat or using this product. AMEC is not liable for damage or personal injury caused either directly or indirectly by the use of this product.

1. I acknowledge the above warning and accept the limitations of this product and the electronic charts
2. I have read the documentation for this product, including its notes, and the C-MAP Data License Agreement, and agree to be bound by the terms of the C-MAP Data License Agreement.

All parts of the product including hardware, software, packaging and documentation are intellectual properties of Alltek Marine Electronics Corporation.

Accept

3.2.1 Setup Wizard

If P200 detects that the MMSI is not set yet, a Setup wizard will help you configure important settings on your P200.

- User will be asked to read and agree the End User License Agreement (EULA).

EULA	Ship Static Data	Ship Dimensions	Setting Summary
<p>End User License Agreement - LIMITATIONS ON USE</p> <p>This product, including the electronic charts, is intended to be used only as an aid to navigation. It should facilitate use of official government charts, not replace them. Only official government charts and notices to mariners contain all the current information needed for safe navigation. This product's features cannot be relied on as complete or accurate. Use and availability may vary locally. It is the captain's responsibility to use official government charts, notices to mariners, caution, sound judgment and proper navigational skills when operating their boat or using this product. AMEC is not liable for damage or personal injury caused either directly or indirectly by the use of this product.</p> <ol style="list-style-type: none">1. I acknowledge the above warning and accept the limitations of this product and the electronic charts2. I have read the documentation for this product, including its notes, and the C-MAP Data License Agreement, and agree to be bound by the terms of the C-MAP Data License Agreement. <p>All parts of the product including hardware, software, packaging and documentation are intellectual properties of Alltek Marine Electronics Corporation.</p> <p style="text-align: center;">Accept</p>			

- The following tabs “Ship Static Data” and “Ship Dimension” tab allow the users to configure the ship’s static data. Please note
 - The input data will be written in P200 immediately
 - MMSI can be set only once, please program your MMSI correctly. If the MMSI needs to be changed for any reason, please contact your dealer who will arrange to have the MMSI reset.
- The “Setting Summary” is mainly to show all the settings on screen again for review.

EULA	Ship Static Data	Ship Dimensions	Setting Summary
Ship's Name		<input type="text"/>	
MMSI		000000000	
Call Sign		<input type="text"/>	
Ship Type		Vessel-Pleasure craft <input type="button" value="v"/>	
Cargo Type		<input type="button" value="v"/>	
Next			

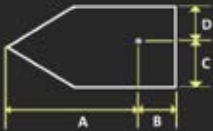

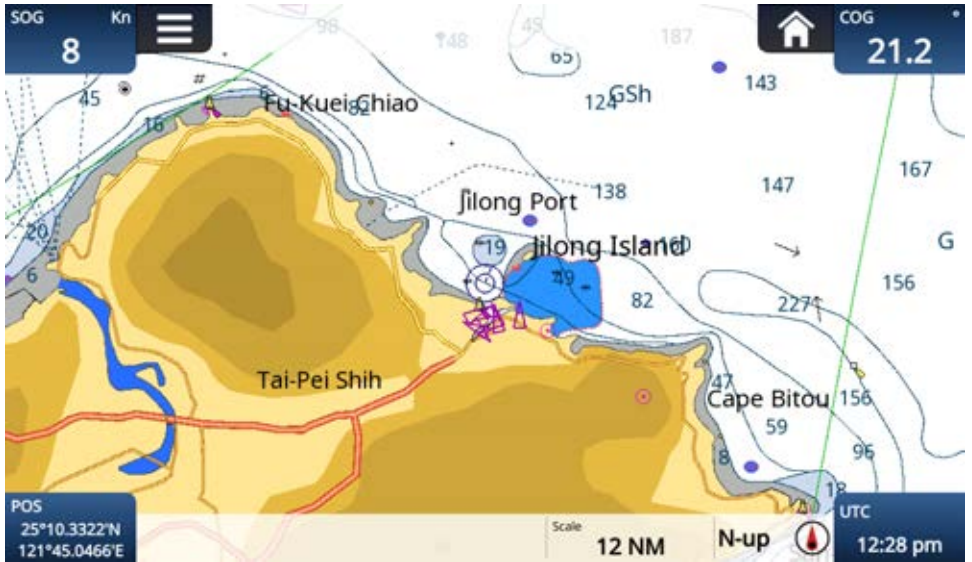

EULA	Ship Static Data	Ship Dimensions	Setting Summary
A (Distance to Bow)		<input type="text" value="0 m"/>	
B (Distance to Stern)		<input type="text" value="0 m"/>	
C (Distance to Port-Side)		<input type="text" value="0 m"/>	
D (Distance to Starboard)		<input type="text" value="0 m"/>	
			
Next			

Once the EULA is confirmed and the ship data set, the chart screen will be displayed which is the starting screen by default.

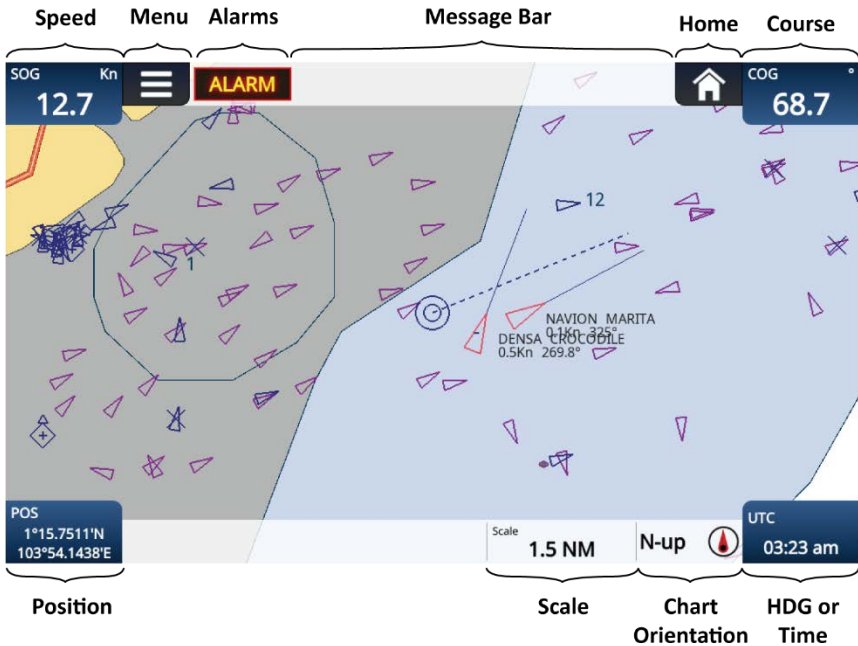

3.3 On-screen Information



Function	Description
Speed	Vessel speed over ground as taken from GNSS satellite data
Course	Vessel course over ground as taken from GNSS satellite data
Position	Vessel position taken from GNSS source
HDG or Time	Heading taken from heading sensor. When HDG is not available, UTC will be displayed on this place which is derived from GNSS satellites or AIS Base Stations. The information of the 4 fields above is only available when the AIS has a valid GPS position fix. Before a GPS position is acquired, an icon  in the lower left corner will be shown.
Scale	Identifies the scale for the chart range displayed
Chart Orientation	North-up, Head-up or Course-up
Home	Unfold the Home panel to navigate the main menu including Chart, Plot view, Targets, Alarms, Messages, Options, Dimmer () , Device Information () and Power ()

Menu	Open the sub menu of the individual menu selected in the Home panel
Alarms	When there are active alarms, acknowledged or unacknowledged, the icon “ALARM” will appear. When pressing on the ALARM icon, the “Alarms” menu will be opened to display all the currently active alarms in a list.

Press the Home button to open the home menu. Press the ☀ button to control the display dimming. When pressing repeatedly on the icon, the brightness will be reduced to minimum, then increased to maximum. Here user can also use “Enter” button toggle between minimum and maximum brightness.

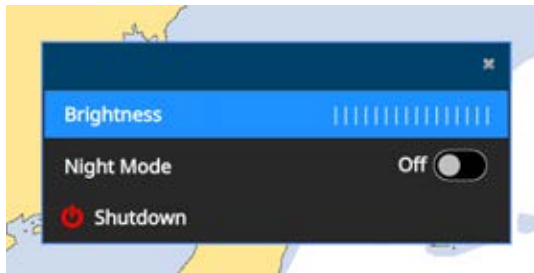

Press the ⏻ Power button can also open the shortcut of dimming control mode. Use the arrow button to either increase (left) or decrease (right) the brightness, or press the power button repeatedly to toggle between minimum and maximum brightness.

User can use “Night Mode” button toggle between day mode and night mode of screen display.

3.4 Chart

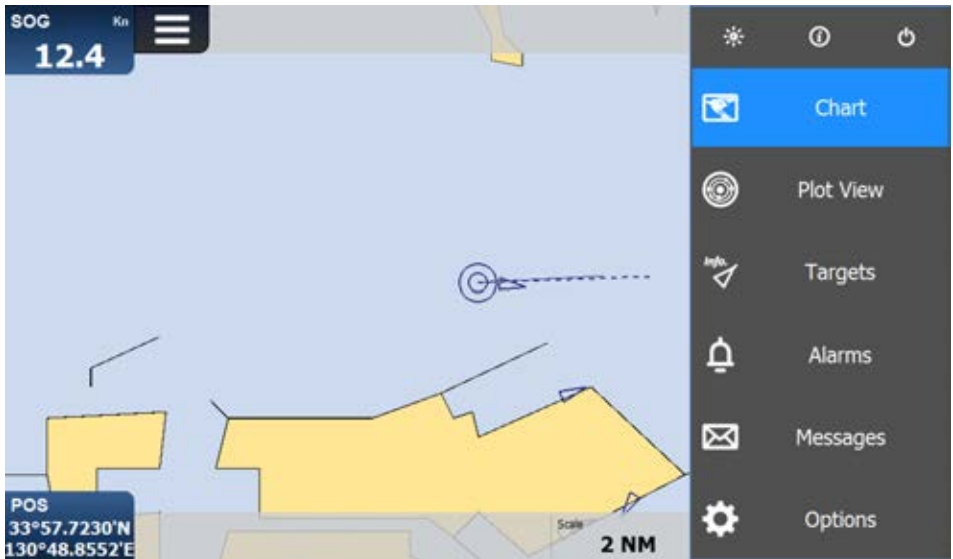

The P200 contains an application which will display AIS targets received, along with its own vessel position on a basic world chart by default. It supports the C-MAP 4D to provide more detailed and high-resolution charts which can be purchased separately by C-MAP dealers. The basic chart operations:

- The chart can be scrolled up, down, left, and right using the touch screen or the arrow keys.
- The chart can be zoomed in or out with pinch gesture or with the zoom-in and zoom-out keys.
- When pressing on any point on the chart with touch screen or arrow keys and Enter key, the longitude and latitude as well as the distance and bearing to own vessel will be displayed.
- When pressing on a vessel icon on the chart, the vessel data including MMSI, COG, SOG, CPA and TCPA will be displayed on the upper right corner. You can also move the cursor with the arrow key to point on a certain vessel and press Enter to see the vessel data. The selected vessel will be highlighted with a yellow circle and the vessel's heading line.

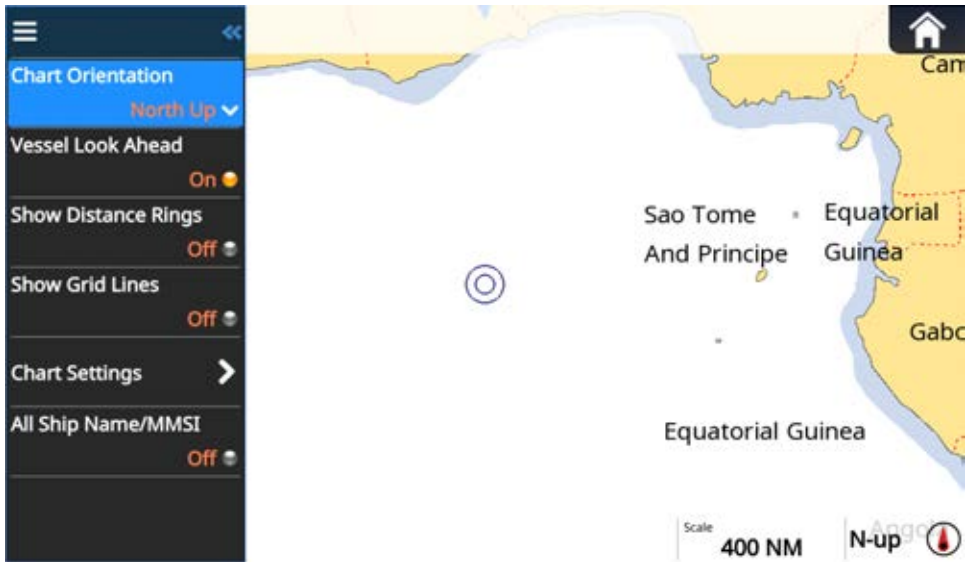

Pressing  menu for the chart is available for more advanced features described as follows:

- Chart Orientation: the chart can be oriented to either North, Heading, or Course Up.
- Vessel Look Ahead: in North-Up mode, the chart will be set so that the own vessel position is always in the centre of the screen. By head-up or course-up, an additional room ahead the vessel will be added for a better navigation.
- Show Distance Rings: shows or hides distance rings. The range of the distance rings varies with the chart scale.
- Show Grid Lines: shows or hides grid lines
- Chart Settings: shows or hides different characters embedded in C-map charts
- All Ship Name/MMSI: shows or hides all ships Name/MMSI on chart for those ships which are within Scale 6NM range (6NM~0.1NM).







3.5 Plot View











Plot view is the screen to show the location of other AIS targets relative to your own vessel. The own vessel's static data is displayed on the blue bar. The plot range from 0.1NM up to 1000NM can be adjusted by pinching the touch screen or pressing the zoom-in or zoom-out buttons. In Plot view's menu, the 3 different orientation modes can be selected.



3.6 Targets

Target List		Friend Ships					
Name/MMSI	Range (NM)	Bearing (°)	CPA (NM)	TCPA (m/s)	OVERSEAS MULAN		
 GP26	6.34	262.7 T	6.25	04:11	Class A - Tanker at anchor		
 373433000	1.04	43.3 T	0.53	04:20	Cargo	No additional information	
 DENSA CROCODILE	1.03	82.6 T	0.13	04:42	Dest.	SPORE	
 OVERSEAS MULAN	1.26	111.3 T	0.75	04:54	ETA	2016/06/21	
 BRITOIL POWER	6	152.6 T	5.9	05:27	COG	357°	
 253445000	6.7	153 T	6.58	06:04	SOG	0.1 Kn	
 241261000	1.63	113.1 T	1.02	06:11	HDG	153°	
Age 09s				Total 470		ROT	0°/min
						POS	1°15.0400'N 103°54.6080'E
						MMSI	538001656
						IMO	9230880
						Call	V7DK3
						Draft	11.5 m
						Dim.	A=279 B=54 C=36 D=24

The 'Target List' screen is the primary screen for displaying AIS targets received. The targets are sorted by default by TCPA. Press the first row of each any column to sort with range, bearing, CPA or TCPA, either in ascending or descending order. Scroll up or down to navigate all the targets with either touch screen or arrow keys. The vessel details of the selected target will be displayed on the right side of the screen. The targets which trigger the CPA/TCPA alert, will be shown on the target list in red. Different symbols are shown for an AIS target depending on the type of target and its status, these are shown in figure below.

	Unknown AIS		AIS AtoN (Real)		Base Station
	AIS Class A		AIS AtoN (Virtual)		AIS SART
	AIS Class B		AIS SAR Aircraft		AIS MOB

3.6.1 Friend Ships

You can use Friend-Ships tag to create your own friend-ship group. Pressing the  button, the function menu will show up. You can Add or Delete a friend ship. Or you can Import/Export friend ships list.

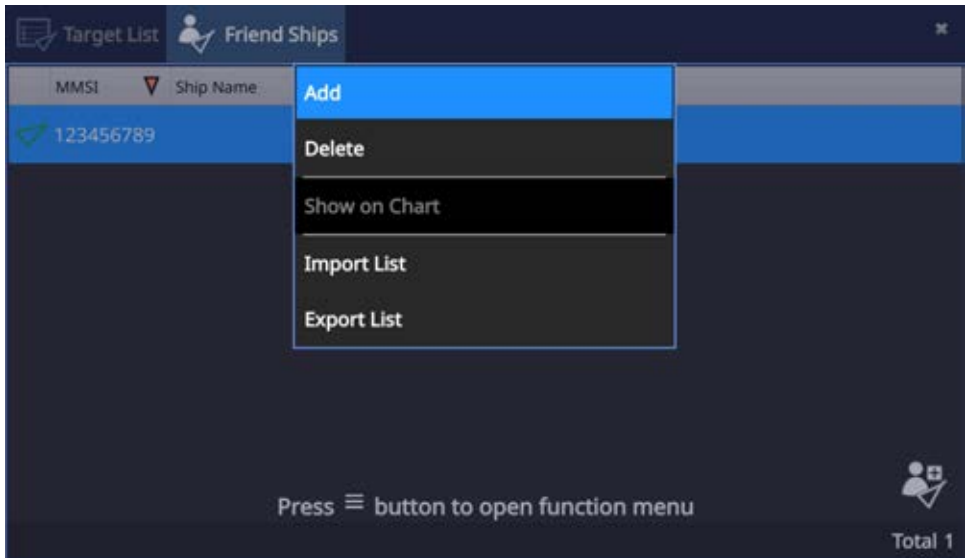
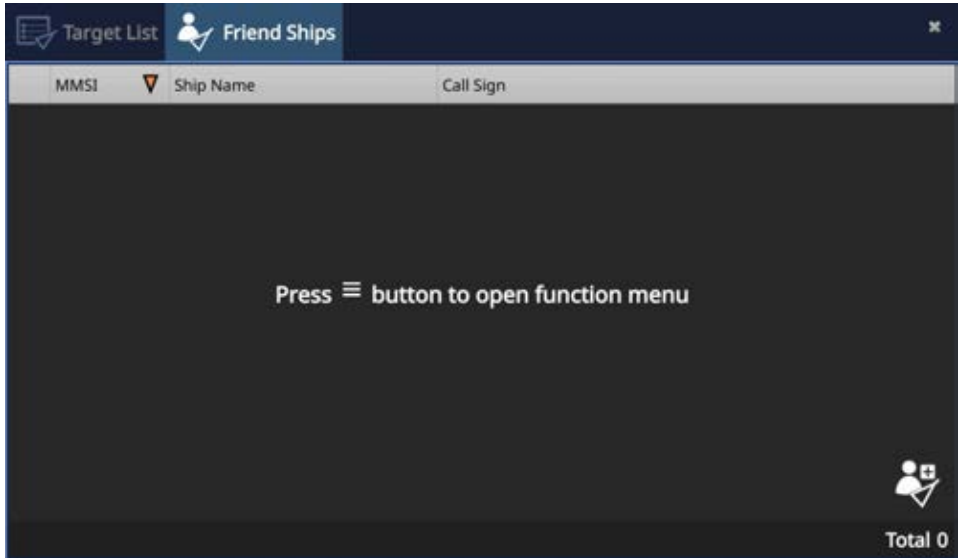

Add a friend ship by entering MMSI directly, or select a target and press  button to add the selected target into Friend Ships group as depicted below.

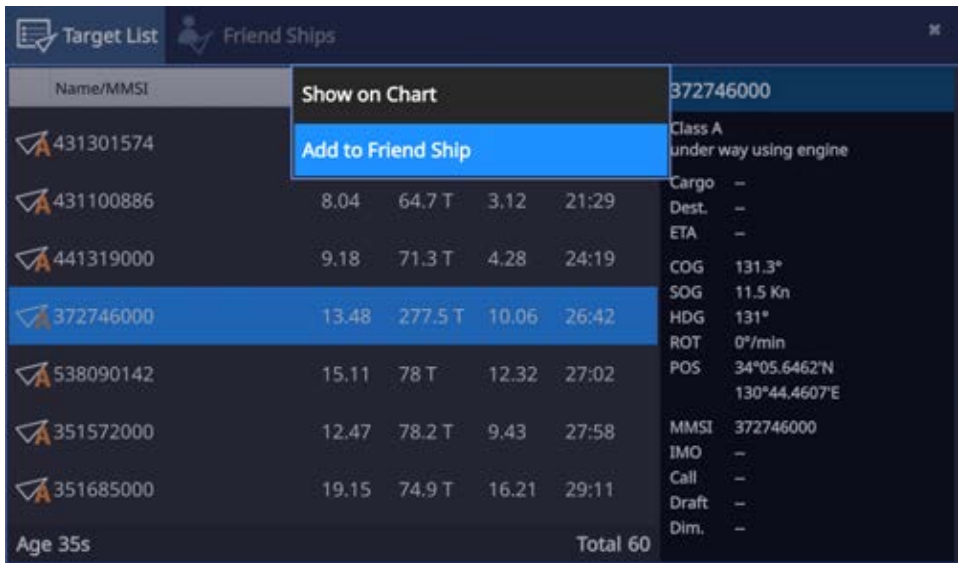
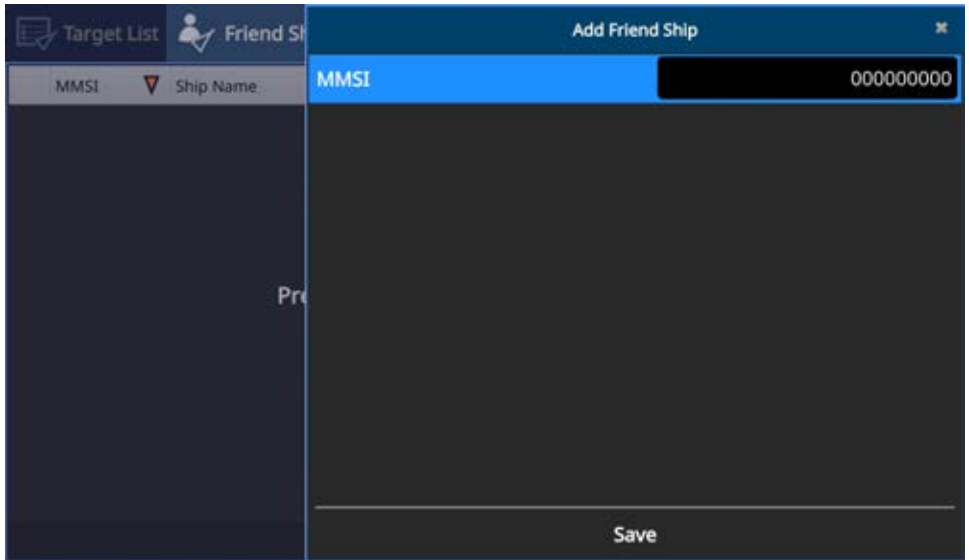

Check Friend Ships list on screen.

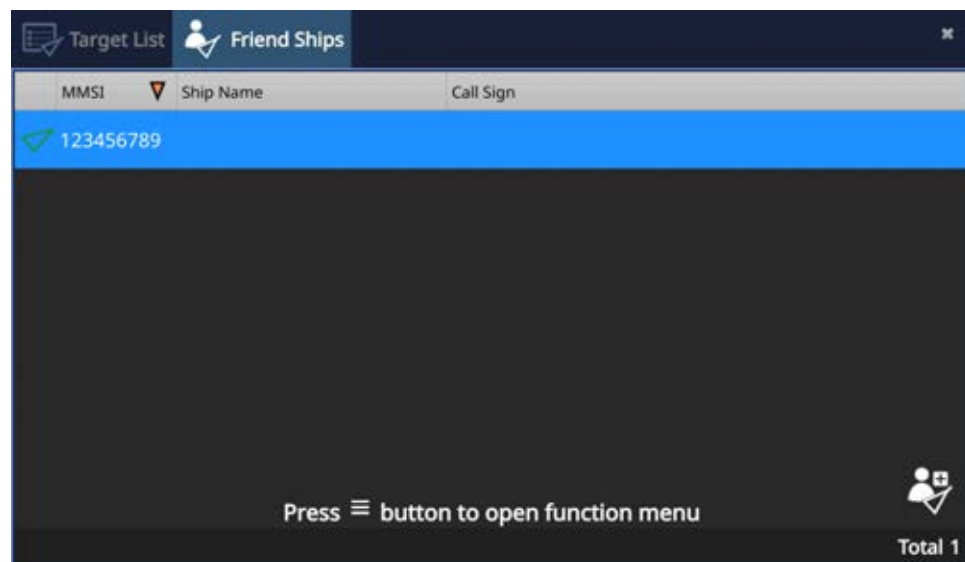

3.7 Alarms

When there are any active alarms coming in, a New Alarm(s) window will pop up. The alarms can be either acknowledged one by one by pressing on the “Acknowledge” button or all at once by pressing the button “Acknowledge All and Show Details” to switch directly to the Alarms menu.

All the active alarms are listed by time stamp in descending order.

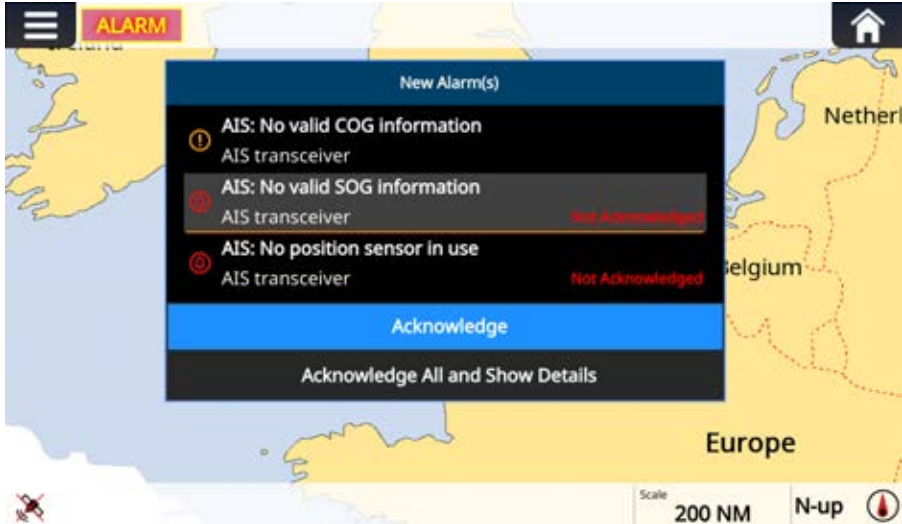

User can find further info about the alarms in the column on right hand side.

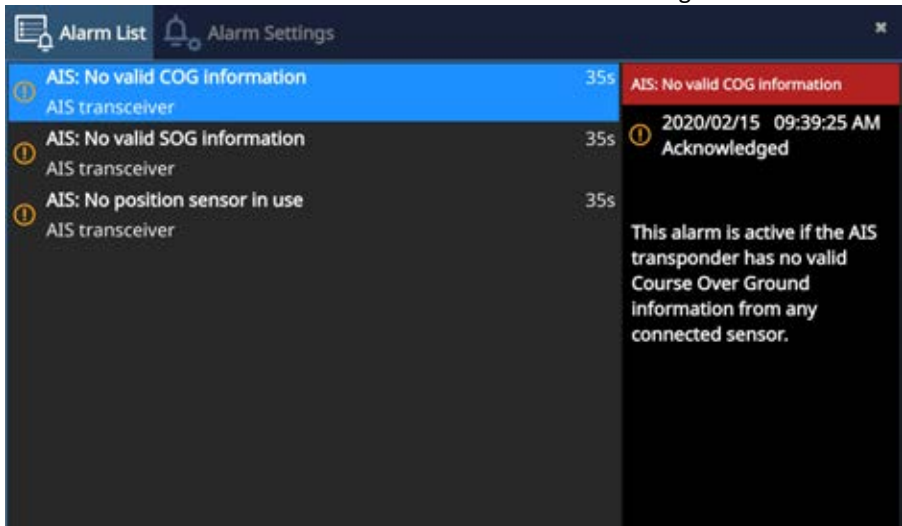

Possible alarm conditions are listed in the Table below.

ALR	Description
AIS: TX Malfunction	A Tx Malfunction alarm is generated if a malfunction in the radio transmitter hardware such as low Tx power or frequency drift is detected.
AIS: Antenna VSWR exceeds limit	The VSWR (Voltage Standing Wave Ratio) of the antenna is checked by every transmission. If it exceeds a given threshold, a VSWR alarm is then triggered.
AIS: RX Channel x malfunction (AIS: Rx channel 1 malfunction, AIS: Rx channel 2 malfunction)	The AIS receivers are continuously monitored. If any part of the receiver hardware should malfunction, an Rx Malfunction alarm is generated for that receiver.
AIS: General failure	This alarm occurs if the transceiver fails to initiate the radio or if a severe hardware failure has occurred.
AIS: No position sensor in use	This alarm occurs if the transceiver receives no valid position (latitude/longitude) from any sensor.
AIS: No valid SOG information	This alarm is active if the AIS transceiver has no valid Speed Over Ground information from any connected sensor.
AIS: No valid COG information	This alarm is active if the AIS transceiver has no valid Course Over Ground information from any connected sensor.

For details about the Alarm Settings, please refer to chapter “Options→General→Alarm Settings”

3.8 Messages

The Messages is an application to receive messages. All the received messages are saved in Inbox. The messages are displayed by time in descending order.

The inbox can save up to 100 messages. When there are more than 100 messages in inbox, the oldest messages will be overwritten.

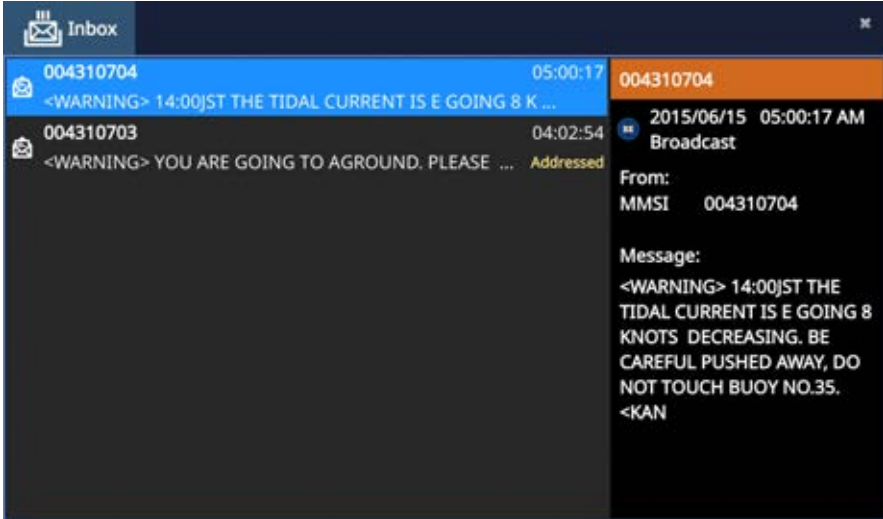

An incoming addressed message will pop up directly in chart and plot view to give the user the opportunity to acknowledge the message.

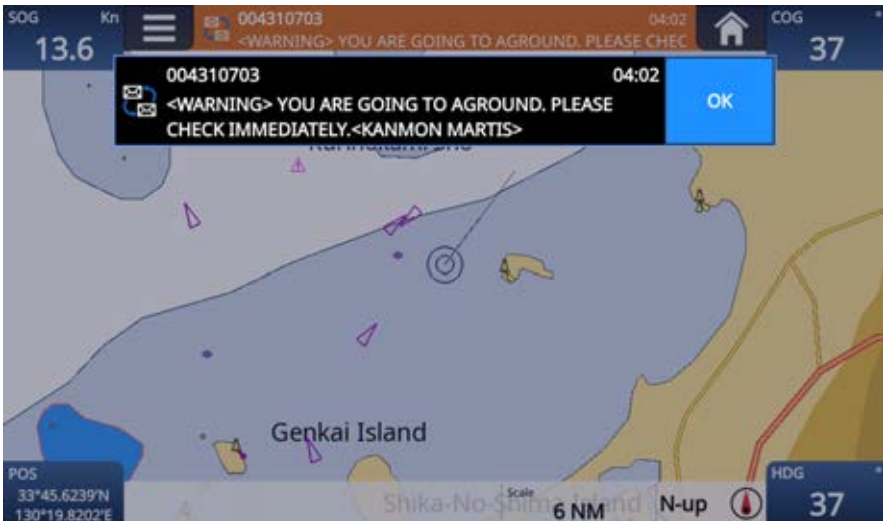

3.9 Options

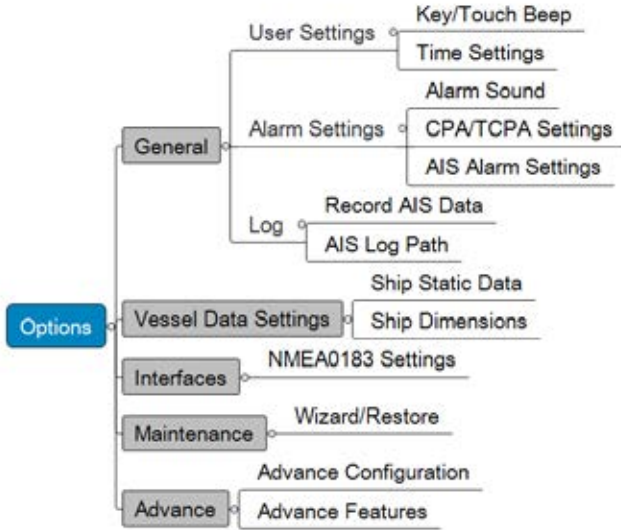

3.9.1 Options→General→User Settings

Parameter Name	Description
Key/Touch Beep	From the scroll-down list, the key/touch beep volume can be selected between Off/Normal/Quiet/Loud
Time Settings	Here the „Time Zone“, “Time Format” and “Date Format” can be user defined per the scroll-down list

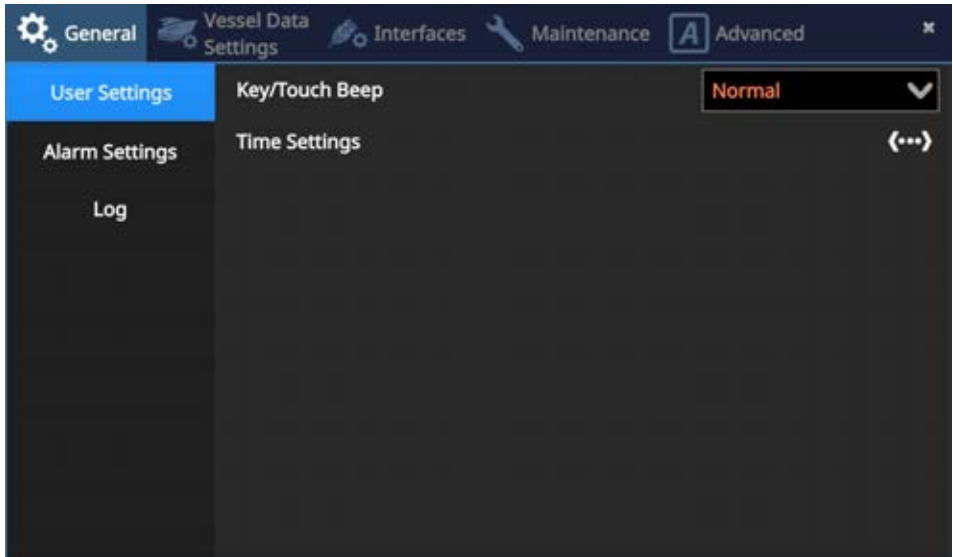

3.9.2 Options→General→Alarm Settings

Parameter Name	Description
Alarm Sound	The alarm sound can be switched on or off here
CPA/TCPA Settings	<p>The AIS transceiver can be configured to identify approaching vessels which fall within certain criteria. The CPA (Closest Point of Approach) defines a boundary around the own vessel upon which, if breached, will trigger an alert.</p> <p>TCPA (Time to Closest Point of Approach) can only be set if CPA is set, and will trigger the alert if the TCPA limit is breached.</p> <p>Any AIS target which triggers CPA or TCPA alarms, will be highlighted with red color on chart, plot view and target list.</p>
AIS Alarm Settings	AIS Alarm (ALR) sentence output can be disabled or enabled individually. Factory default setting is "Off" (disabled).

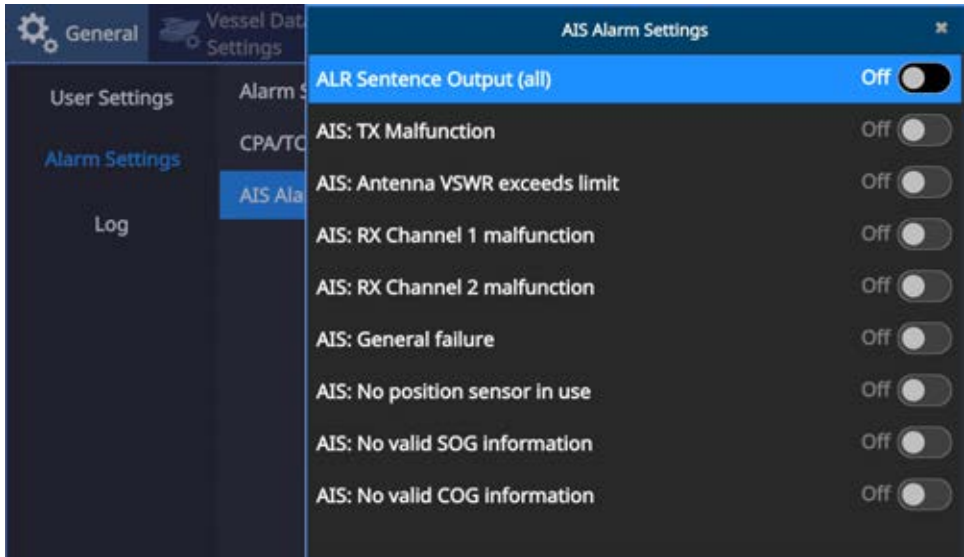

3.9.3 Options→General→Log

Parameter Name	Description
SD Card Slot 2	When an SD card is inserted into slot 2, it's total and remaining capacity will be displayed here
Record AIS Data	To switch On/Off AIS data logging
AIS Log Path	The AIS Log Path is just to state that a folder named "AIS_Log" will be generated automatically in the SD card's root directory after the SD card is inserted into slot 2

3.9.4 Options→Vessel Data Settings

Parameter Name	Description
Ship Static Data	Use the software keyboard to complete the inputs of ship name, MMSI (Maritime Mobile Service Identity reported by own ship) and call sign. WARNING: The MMSI number can only be entered once. Be sure to enter the correct MMSI number, as it cannot be corrected if entered incorrectly. Select the ship type (and cargo type when available) according to ITU 1371-3 from the drop list.
Ship Dimensions	Enter the vessel dimensions by appointing the position of your GPS antenna

3.9.5 Options→NMEA 0183 Settings

Parameter Name	Description
Port #1 Transmit Baud Rate	The default Port #1 Transmit Baud Rate is 38400-bps. Different baud rate can be assigned respectively.
Port #1 Receive Baud Rate	The default Port #1 Receive Baud Rate is 38400-bps. Different baud rate can be assigned respectively.
Port #2 Transmit/Receive Baud Rate	The default Port #2 Transmit/Receive Baud Rate is 4800-bps. Input and output share the same baud rate.

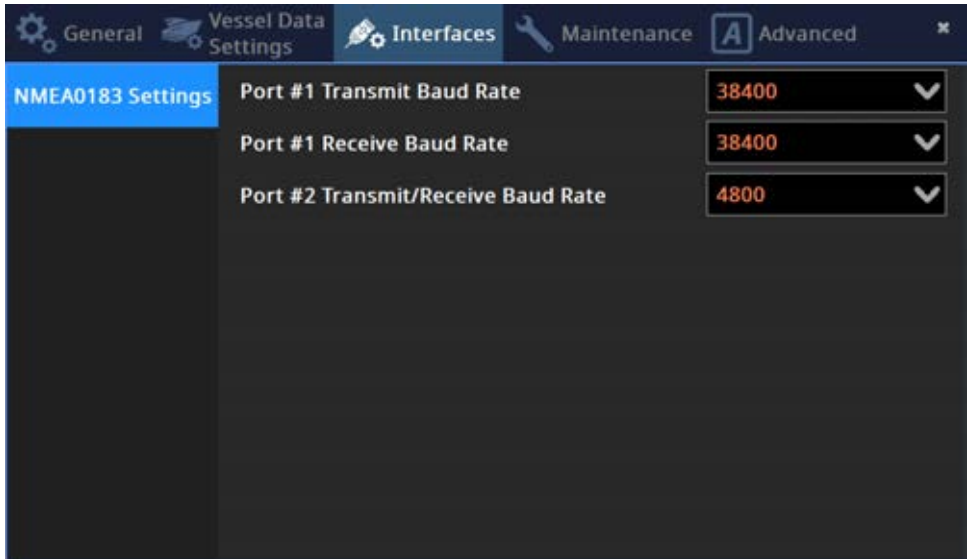

3.9.6 Options→Maintenance

Parameter Name	Description
Setup Wizard	The wizard will help user finish the initial settings including EULA confirmation, SD card setup and vessel data configuration.
Restore Factory Settings	All configuration parameters except MMSI and vessel data can be set to default values.

3.9.7 Options→Advanced

Parameter Name	Description
Advanced Configuration	Silent Mode: switch to “ON” to activate the Silent mode or “OFF” to resume AIS transmission.
Advanced Features	Language: change the language in all the menus and views.

3.10 Function Key (Fn) Operation

3.10.1 Go to Own Vessel

When pressing the Fn key and select “Go to Own Vessel”, your vessel on screen will be centered.



3.10.2 Man Overboard (MOB) Activation

When pressing the Fn Key and select “Man overboard”, you can create a Man Overboard (MOB) for an emergency. This means:

- A waypoint at the vessel’s current position is created
- The display switches to chart panel, centered on vessel’s position
- Navigational information (bearing, range and time to go based on vessel’s speed) will be displayed until MOB is cancelled
- Delete MOB: Press Fn key again and confirm the option “Cancel Man Overboard”.

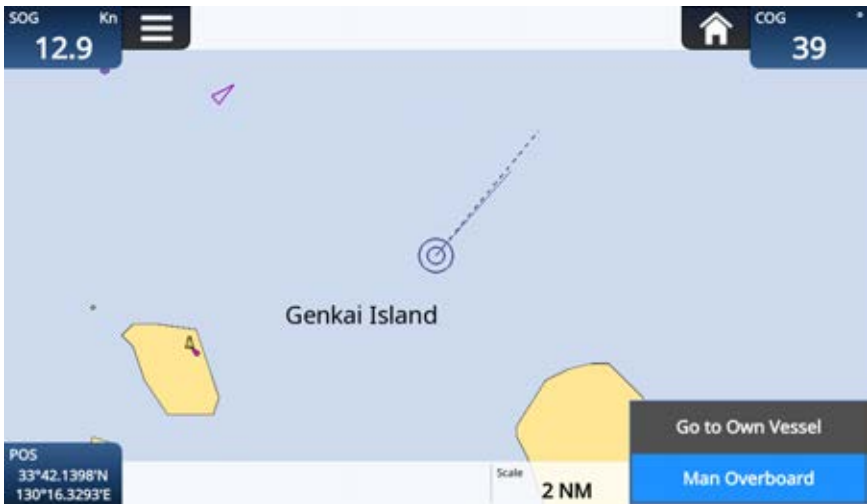

3.11 Device Information



The Device Information can be accessed by pressing on the  icon, or pressing the lower-left corner on chart or plot view where the latitude and longitude are displayed.

The default screen of Device Information is GNSS Status.

3.11.1 GNSS Status

The GNSS Status page shows the current GPS signal strength along with GPS position fix information. Satellite signals shown in green are actively being used to calculate a position. If a position fix is not available, then no position information will be displayed and the signal strength bars will be shown in blue.

The “Fix” mode indicates how the position fix is done:

- 2D means a two-dimensional position fix that includes only horizontal coordinates. It requires a minimum of three visible satellites.
- 3D means a three-dimensional position fix that includes horizontal coordinates plus elevation. It requires a minimum of four visible satellites or more.



3.11.2 Information

Parameter Name	Description
System Check	Device operating status can be checked at this tab, including MMSI number, GNSS position fix, AIS receive, AIS transmit, and silent mode (Tx Off) setting. To get latest device status update again, please press the "Refresh"
SD Card Slots	The "SD Card Slots" reminds that SD Card slot 1 is dedicated for C-MAP card compatible with C-MAP 4D format only. When an SD card in slot 2 is detected, it's total and remaining capacity will be displayed here
Software Info.	This view displays the software versions running on the device as well as its serial number which are useful information for error diagnostics.
System Updates	When micro SD card containing firmware files is detected (for the platform or the AIS transceiver), the current version and the new version will be displayed side by side for the user to decide whether a firmware upgrade is necessary. When yes, press the button "Upgrade Now" and the firmware upgrade will be done.

GNSS Status	Information	Help
System Check	MMSI	000000000
	GNSS (GPS) position fixed	Lost
SD Card Slots	Has AIS received a position report?	Yes
Software Info.	Has AIS transmitted a position report?	No
	Silent Mode (Tx Off)	Disabled
System Updates	Refresh	

GNSS Status	Information	Help
System Check	SD Card Slot 1 (for C-Map card)	
SD Card Slots	SD card not detected!	
Software Info.	SD Card Slot 2 (for data recording and firmware upgrade)	
System Updates	0.41GB free (Total 15.55GB)	
		

GNSS Status	Information	Help
System Check	SD Card Slot 2 (for data recording and firmware upgrade)	
SD Card Slots	1.56GB free (Total 15.55GB)	
Software Info.	Current Platform Version	V2.4.0.2043
System Updates	New Update Available! Version is V2.4.0.2043	
	Current AIS Transceiver Firmware	V1.2.8.09
	No file available!	
Click Here to Start Upgrade Process		

3.11.3 Help

Parameter Name	Description
Support	To display manufacturer's service email address and other contacts for facilitating technical support
About	Copy right statement of the manufacturer
EULA	End User License Agreement
License	To display other licenses used in this device

4 SPECIFICATIONS

4.1 Product Specifications

APPLICABLE STANDARDS	
IEC 60945 Ed. 4:2002	EN 303 413 V1.1.1
IEC 62287-1 Ed. 3:2017 (P200-CS)	EN 301 489-1 V2.1.1 / EN 301 489-19 V2.1.1
IEC 62287-2 Ed. 2:2017 (P200-SO)	EN 301 489-1 V2.1.1 / EN 301 489-17 V3.1.1
IEC 61108-1 Ed. 2:2003	EN 301 843-1 V2.2.1
ITU-R M.1371-5:2014	EN 62311:2008
EN 300 328 V2.2.2	
EN 62368-1:2014 + A11:2017	
AIS TRANSCEIVER	
Frequency Range	156.025 MHz ~ 162.025 MHz
Access Scheme	SOTDMA or CSTDMA depends on the class B transponder equipped
Channel Bandwidth	25 KHz
Modulation	GMSK / FM
Data Rate	9,600 bps
Number of AIS Transmitter	1
Number of AIS Receiver	2 (one time-shared between AIS and DSC)
Number of DSC Receiver	1 (time-shared between AIS and DSC)
AIS Channel 1	CH 87B (161.975 MHz)
AIS Channel 2	CH 88B (162.025 MHz)
Tx Power Output	SOTDMA: 5 Watt (37 dBm ± 1.5 dB) or 1 Watt (30 dBm ± 1.5 dB) CSTDMA: 2 Watt (33 dBm ± 1.5 dB)
Rx Sensitivity	< -107 dBm @ 20% PER
DSC RECEIVER	
Modulation	1,300 Hz / 2,100 Hz FSK
Data Rate	1,200 bps ± 30 ppm
GPS RECEIVER (INTEGRATED)	
Receiving Channels	50 channels
Accuracy	IEC 61108-1 compliant
Output Rate	1 Hz
Time to First Fix	< 60s
LCD DISPLAY	
Display Size	7 inches
Screen Brightness	850 nits
Display Resolution	1024x600

Viewing Angles	typ./ min. 85° / 80° top/bottom, typ./ min. 85° / 80° left/right
Backlight Color	White LED
POWER SUPPLY	
Power Input / Current (max)	P200-SO: 12-24 VDC / 2.3-1.1A max P200-CS: 12-24 VDC / 2.4-1.9A max
CONNECTION INTERFACE	
VHF Antenna Connector	SO-239 (female)
GPS Antenna Connector	TNC (female)
NMEA 0183 Connector	12 pins (with 8 wires connecting to external device)
NMEA 2000 Connector	5 pins, standard connector LEN=1
Ethernet Port (Optional)	8 pins (with a cable connecting to RJ45 connector)
Power Connector	3 pins
KEYPAD & SD CARD	
Power On/Off Key	A dedicated keypad for power on/off
Keypad	Home, Menu, Room-in, Room-out, Esc, Enter, Func, Power, Up-down-left-right
Micro-SD Card	Support two micro-SD cards, one for C-Map charts, one for firmware upgrade
ENVIRONMENTAL	
Operating Conditions	IEC 60945 “protected” category
Operating Temperature	-15°C ~ 55°C
Storage Temperature	-30°C ~ 70°C
Humidity	93% relative humidity (RH) for 10 hours @40°C
Compass Safe Distance	0.55 m (standard-magnetic) 0.45 m (steering-magnetic)
Waterproof Rating	IP67 with card door closed
PHYSICAL	
Width	233.63 mm (9.20 inches)
Height (Main Unit)	150.00 mm (5.91 inches)
Depth	77.56 mm (3.05 inches) (exclude connector)
Weight	1045g (without Ethernet connector)
Wi-Fi (OPTIONAL)	
Tx Transmit Power	18 dBm (EIRP)
Frequency Range	2412 MHz ~ 2472 MHz
Wi-Fi Antenna	Balance Flex Antenna with 2.8 dBi

4.2 Dimensions

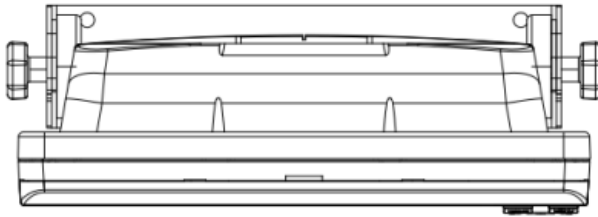

Top1
233.63

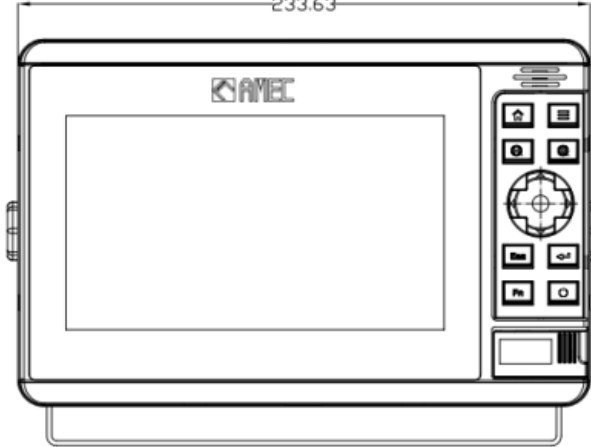

Front1

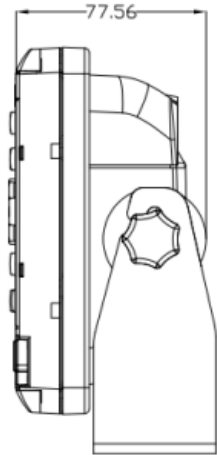

77.56

Right1

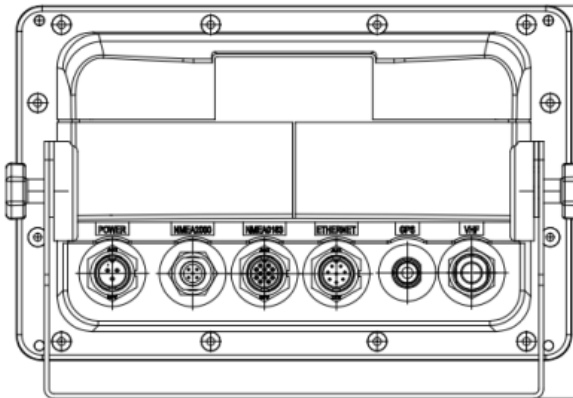

Back1

165.72

4.3 Supported NMEA 0183 Sentences

Transmit	
Sentence	Description
GGA	Global Positioning System Fix Data
GSA	GNSS DOP and Active Satellites
GSV	GNSS Satellites In View
GLL	Geographic Position – Latitude/Longitude
RMC	Recommended Minimum Specific GNSS Data
VDO	AIS VHF Data-Link Own-Vessel Report
VDM	AIS VHF Data-link Message
Receive	
Sentence	Description
DTM	Datum Reference
GBS	GNSS Satellite Fault Detection
GSA	GNSS DOP and Active Satellites
HDT	Heading, True
RMC	Recommended Minimum Specific GNSS Data
ROT	Rate Of Turn

4.4 NMEA 2000 PGN Information

Transmit	
PGN	Description
59392	ISO Acknowledgment
59904	ISO Request
60928	ISO Address Claim
126464	PGN List - Transmit PGN's group function
126996	Product Information
129025	Position Rapid Update
129026	COG SOG Rapid Update
129029	GNSS Position Data
129038	AIS Class A Position Report
129039	AIS Class B Position Report
129040	AIS Class B Extended Position Report
129041	AIS Aids to Navigation (AtoN) Report
129539	GNSS DOPs
129540	GNSS Sats in View
129792	AIS DGNSS Broadcast Binary Message
129793	AIS UTC and Date Report
129794	AIS Class A Static and Voyage Related Data
129795	AIS Addressed Binary Message
129796	AIS Acknowledge
129797	AIS Binary Broadcast Message
129798	AIS Class A Position Report
129800	AIS UTC/Date Inquiry
129801	AIS Addressed Safety Related Message
129802	AIS Safety Related Broadcast Message
129803	AIS Interrogation
129804	AIS Assignment Mode Command
129805	AIS Data Link Management Message
129806	AIS Channel Management
129807	AIS Group Assignment
129809	AIS Class B "CS" Static Data Report, Part A
129810	AIS Class B "CS" Static Data Report, Part B
Receive	
PGN	Description
59392	ISO Acknowledgment
59904	ISO Request
60928	ISO Address Claim
127250	Vessel Heading

127258	Magnetic Variation
129026	COG & SOG, Rapid Update
129029	GNSS Position Data
129539	GNSS DOPs

5 TROUBLESHOOTING

P200 receives AIS signals normally, but no one in the surrounding can see me, why?

- AIS Class B transmission range limitation: an AIS Class B transmitting range of 5-7 miles in perfect conditions. The AIS receiver in the transceiver will typically see Class A vessels that are 20-30 miles away or even more in excellent conditions. The major reason is that all AIS Class B transmit at 2 watts vs. the 12.5 watts that Class A transceivers typically use. This difference in power impacts on the transmission range of each transceiver type. For this reason, it is quite possible that Class A vessel can be seen, but Class B vessel might not be seen.
- VHF antennas interference: if you are using a dedicated AIS/VHF antenna for your transceiver, be sure that it is placed at least 6 ft (1.83 m) away from other VHF antennas or vertical metal objects and ideally install the antenna on a different vertical plane from other VHF antennas. In several tests, mounting two VHF antennas next to another typically reduces the transmitting range to both antennas by 50-70%.
- GPS is not fixed: If your GPS antenna is not connected or setup correctly, your transceiver will see other vessels fine, but you will not be sending out your vessel position. All AIS transceivers need a good GPS fix before it can send out any type of transmission. The color and state of the LEDs on the transceiver indicate if the unit is in transmission mode or not.
- The location of VHF antenna is directly related to AIS transmitting range. The VHF antenna should be installed at mast as high as possible.

Even though my P200 is transmitting, why do some vessels with AIS take a long time to see my vessel name or not see it at all?

- AIS Class B users should keep in mind that Class B transceivers do not broadcast position updates as often as Class A commercial transceivers. As with Class B transceivers, the full static information, such as vessel's names, the transmission is broadcasted every 6 minutes; however, MMSI and dynamic information, such as position, update will only be sent out every 3 minutes if the vessel is moving slower than 2 knots. To add to this, if the receiving party is using non-standard dual channel receiver (a single channel receiver), then in perfect conditions, the receiver will get your full static information every 12 minutes and your MMSI and dynamic information every 6 minutes if you are moored.

My MMSI is being received by other vessels but my vessel name is not shown on their chart plotter or PC, why?

- Older software and AIS displays may not be fully compatible with Class B transceivers. In some of these cases, older equipments might only have Class B

vessel show up on their displays with just MMSI number without the vessel name. This is usually due to the receiving device not knowing how to process the Message 24 static data from Class B transceivers. Please contact the chart plotter maker and ask for software upgrades (for these older chart plotters) to resolve this issue.

If you still encounter difficulties to set up or operate P200 correctly, please email to service@alltekmarine.com for further instructions.

6 ABBREVIATIONS

AIS	Automatic Identification System
AtoN	Aids to Navigation
COG	Course Over Ground
CPA	Distance to Closest Point of Approach
CSTDMA	Carrier-Sense Time Division Multiple Access
SOTDMA	Self-Organized Time Division Multiple Access
DSC	Digital Selective Calling
ECS	Electronic Chart System
ETA	Estimated Time of Arrival
FM	Frequency Modulation
GPS	Global Positioning System
GMSK	Gaussian Minimum Shift Keying
GNSS	Global Navigation Satellite System
HDG	Heading
IMO	International Maritime Organization
MMSI	Maritime Mobile Service Identity
NM	Nautical Miles (1 NM = 1 852 m)
NMEA	National Marine Electronics Association
PER	Packet Error Rate
POS	Position
Rx	Receive
SART	Search and Rescue Transmitter
SOG	Speed Over Ground
TCPA	Time to Closest Point of Approach
TDMA	Time Division Multiple Access
Tx	Transmit
UTC	Universal Time Co-ordinated
VDL	VHF Data Link
VHF	Very High Frequency
VSWR	Voltage Standing Wave Ratio
VTS	Vessel Traffic Services

FCC INTERFERENCE STATEMENT

NOTE: This equipment has been tested and found to comply with the limits for a Class A digital device, pursuant to part 15 of the FCC Rules. These limits are designed to provide reasonable protection against harmful interference when the equipment is operated in a commercial environment. This equipment generates, uses, and can radiate radio frequency energy and, if not installed and used in accordance with the instruction manual, may cause harmful interference to radio communications. Operation of this equipment in a residential area is likely to cause harmful interference in which case the user will be required to correct the interference at his own expense.

This device complies with Part 15 of the FCC Rules. Operation is subject to the following two conditions:

- 1) This device may not cause harmful interference, and
- 2) This device must accept any interference received, including interference that may cause undesired operation.

Any changes or modifications not expressly approved by AMEC for compliance could void of the user's authority to operate the equipment.

RF Exposure Warning

WARNING: This device generates and radiates RF electromagnetic energy and must be installed and operated according to the instructions contained in this manual. Failure to do so may result in product malfunction and/or exposure to potentially harmful levels of radio frequency radiation.

WARNING: Never operate this device unless it is properly connected to a VHF antenna.

The system has a Maximum Permissible Exposure (MPE) radius of 1.2m from the antenna. This has been determined assuming the maximum power of the transmitter and using a standard half-wave monopole VHF antenna with a maximum gain of 3dBi and termination impedance of 50 ohms.

When installing the antenna and operating the equipment consider the following:

- Higher gain VHF antennas will require a larger MPE radius.
- Do not operate the unit when anyone is within the MPE radius of the antenna.
- The antenna should not be co-located or operated in conjunction with any other transmitting antenna.

DECLARATION OF CONFORMITY

Hereby, Alltek Marine Electronics Corp. (AMEC) declares that this P200 is in compliance with the essential requirements and other relevant provisions of Directive **2014/53/EU RED**.

A copy of the Declaration of Conformity can be obtained on-line from under “Download”:
<http://www.alltekmarine.com/>

Industry Canada Notice

This AIS class B digital device complies with Canadian ICES-003.
Cet dispositif numérique de la AIS classe B est conforme à la norme NMB-003 du Canada.

This device contains licence-exempt transmitter(s)/receiver(s) that comply with Innovation, Science and Economic Development Canada’s licence-exempt RSS(s). Operation is subject to the following two conditions:

- 1.This device may not cause interference.
- 2.This device must accept any interference, including interference that may cause undesired operation of the device.

L’émetteur/récepteur exempt de licence contenu dans le présent appareil est conforme aux CNR d’Innovation, Sciences et Développement économique Canada applicables aux appareils radio exempts de licence.

L’exploitation est autorisée aux deux conditions suivantes :

- 1.L’appareil ne doit pas produire de brouillage;
- 2.L’appareil doit accepter tout brouillage radioélectrique subi, même si le brouillage est susceptible d’en compromettre le fonctionnement.

AMEC WORLDWIDE WARRANTY

Limited warranty

Subject to the terms, conditions and limitations set forth in this Worldwide Limited Warranty (hereinafter the “Warranty”), KODEN warrants that its products, when properly installed and used, will be free from defects in material and workmanship for a period of twelve (12) months, from the date of first purchase (the ‘Warranty Period’)

For the purposes of this warranty, ‘date of first purchase’ means the date that the product was purchased by the first retail customer, or by the institutional customer, or in the case of a product installed on a new vessel or any other marine related platform by a certified AMEC original equipment manufacturer (a ‘AMEC OEM’), the date that such vessel was purchased by the first retail customer.

AMEC will, at its sole option, repair or replace any defective products or components returned during the Warranty Period in accordance with the terms, conditions and limitations set forth below. Such repairs or replacement will be the sole remedy of the customer under this Warranty.

Standard Warranty Service

To qualify for standard warranty service the product must be returned to a AMEC-certified service agent (i) within the Warranty Period, and (ii) within thirty (30) days of the alleged product failure. Any products returned must be securely packaged and sent pre-paid and insured to AMEC or to a AMEC-certified service agent. All products returned must be accompanied by a copy of the original sales receipt to be eligible for standard warranty service.

Other conditions

This Warranty is fully transferable provided that you furnish the original proof of purchase to the AMEC -certified service agent. This Warranty is void if the seal label is removed or defaced.

THE LIABILITY OF AMEC TO A CUSTOMER UNDER THIS WARRANTY, WHETHER FOR BREACH OF CONTRACT, TORT, BREACH OF STATUTORY DUTY OR OTHERWISE SHALL IN NO EVENT EXCEED AN AMOUNT EQUAL TO THE TOTAL PURCHASE PRICE OF THE PRODUCT GIVING RISE TO SUCH LIABILITY AND IN NO EVENT SHALL AMEC BE LIABLE FOR SPECIAL, INCIDENTAL, CONSEQUENTIAL OR INDIRECT DAMAGES OR LOST OF GOODWILL, REPUTATION, LOSS OF OPPORTUNITY OR INFORMATION, DATA, SOFTWARE OR APPLICATIONS.

In the event that any term or provision contained in this Warranty is found to be invalid, illegal or unenforceable by a court of competent jurisdiction, then such provision shall be deemed modified to the extent necessary to make such provision enforceable by such court, taking into account the intent of the parties. All AMEC products sold or provided hereunder are merely aids to navigation. It is the responsibility of the user to exercise discretion and proper navigational skill independent of any AMEC product.

NOTE:



NOTE:



Alltek Marine Electronics Corporation

14F-2, No. 237, Sec. 1, Datong Rd.,
Xizhi Dist., New Taipei City, 22161, Taiwan

Tel: +886 2 8691 8568

Fax: +886 2 8691 9569

Email: service@alltekmarine.com

Website: www.alltekmarine.com